



**Portable Laser Aerosolspectrometer  
and Dust Monitor  
Model 1.108/1.109**





## Content

<b>CONTENT</b>	<b>3</b>
INDEX OF FIGURES .....	6
INDEX OF TABLES .....	6
 <b>GENERAL</b>	 <b>7</b>
ANNOTATION .....	7
MEANING OF THE USED SYMBOLS .....	7
 <b>1 IMPORTANT HINTS FOR THE CUSTOMER</b>	 <b>8</b>
1.1 SAFETY REGULATIONS .....	8
1.2 ELECTRIC SAFETY .....	8
1.3 LASER SAFETY .....	9
1.4 TRANSPORTATION .....	9
 <b>2 MODEL 1.108 AND 1.109</b>	 <b>10</b>
2.1 PARTICLE MEASUREMENT WITH GRIMM'S DUAL-TECHNOLOGY .....	10
2.2 MEASURING PRINCIPLE .....	11
2.3 CALIBRATION .....	13
2.4 LIST OF ACCESSORY .....	16
2.5 TECHNICAL DATA .....	18
Nominal rating 1.108 and 1.109 .....	18
Technical data 1.108 and 1.109 .....	18
2.6 PNEUMATICS .....	20
 <b>3 CONTROL ELEMENTS</b>	 <b>21</b>
3.1 LCD-DISPLAY .....	22
3.2 DATA STORAGE CARD .....	22
Starting up and initiating the data storage card .....	23
Data preservation and storage times .....	24
3.3 KEYPAD AND KEY FUNCTIONS .....	25
Key functions in the standby mode .....	26
Key functions in the operational mode .....	29
3.4 SAMPLE INLET .....	32
3.5 ANALOG INPUT .....	32
3.6 CONNECTION FOR POWER SUPPLY .....	33
3.7 RS-232 INTERFACE .....	33
3.8 FILTER CHAMBER .....	33
3.9 PTFE-FILTER .....	34
3.10 WARNING FOR LASER RADIATION .....	34

3.11	CALIBRATION LABEL.....	34
3.12	MODEL DESIGNATION AND SERIAL NUMBER.....	34
3.13	SAMPLE OUTLET WITH END CAP .....	34
3.14	LOCKING FEATURE FOR BATTERY CASE AND LEAD STORAGE BATTERY.....	35
	Safety instructions and lead storage battery maintenance: .....	35
<b>4</b>	<b>SYSTEM OPERATION</b>	<b>36</b>
4.1	INITIATION.....	36
4.2	MEASUREMENT .....	38
4.3	MEASUREMENT MODE AND DATA PRESENTATION .....	38
4.4	GRAVIMETRIC CONTROL OF THE DUST MASS.....	39
	Determination of the gravimetric factor (C-factor).....	40
<b>5</b>	<b>HYPERTERMINAL VIA RS-232 INTERFACE</b>	<b>41</b>
5.1	TRANSMISSION PROTOCOL.....	41
5.2	ESTABLISHING AN HYPERTERMINAL CONNECTION.....	41
5.3	RS-232 COMMANDS .....	43
5.4	SERVICE MODE SETTINGS.....	51
5.5	RS-232 DATA TRANSMISSION .....	52
	model 1.108, version 8.60 operational mode particle concentration (Counts).....	54
	model 1.108, version 8.60, operational mode mass (Normal Dust Mode).....	56
	modell 1.109, version 12.30 operational mode particle concentration (Counts) .....	58
	modell 1.109, version 12.30 Operational Mode particle mass (Normal Dust Mode) .....	61
<b>6</b>	<b>MAINTENANCE AND CLEANING</b>	<b>63</b>
6.1	FILTER CHAMBER.....	63
6.2	FILTER CHANGE.....	63
6.3	CLEANING THE OPTICAL CHAMBER .....	64
6.4	HOUSING .....	64
6.5	INTERNAL RINSING AIR FILTER.....	64
6.6	K-LINE, TEST OF FUNCTIONALITY OF THE OPTICAL CELL, LASER DIODE AND PHOTO DIODE.....	64
<b>7</b>	<b>ACCESSORY</b>	<b>67</b>
7.1	SAMPLE INLETS .....	67
	Radial symmetric sampling head (model 1.111) .....	67
	Clean room sampling heads (model 1.151A) .....	68
	Isokinetic sampling head for 2 up to 25 m/s (model 1.152).....	68
	High pressure diffuser for compressed air (model 7.910) .....	70
7.2	BLACK LEATHER SPECTROMETER PROTECTION BAG WITH SHOULDER STRIP (MODEL 1.145A) .	70
7.3	ACOUSTIC AND VISUAL ALARM UNIT (MODEL 1.147).....	70
7.4	MINI FILTER FOR ZERO TEST (MODEL 1.148) .....	70
7.5	SENSOR FOR TEMPERATURE AND RELATIVE HUMIDITY (MODEL 1.153FH) .....	71
7.6	SENSOR FOR TEMPERATURE, RELATIVE HUMIDITY AND AIR VELOCITY (MODEL 1.154).....	71

7.7	PLUG FOR ANALOG SOCKET.....	71
7.8	PAH-SENSOR (MODEL 1.301) AND ADAPTER KIT (MODEL 1.301-HLX).....	72
7.9	NANOCHECK MODEL 1.320 AND ADAPTER KIT 1.365-HLX.....	73
7.10	WEATHER PROTECTION HOUSING (MODEL 165) .....	74
<b>8</b>	<b>WARRANTY</b>	<b>75</b>
<b>9</b>	<b>TRANSPORT</b>	<b>76</b>
<b>10</b>	<b>REPAIR</b>	<b>77</b>
	<b>INDEX</b>	<b>78</b>
	<b>ANNEX</b>	<b>80</b>
<b>11</b>	<b>SOFTWARE MODEL 1.178</b>	<b>81</b>

## Index of figures

Figure 1: Measuring principle series 1.108 and 1.109.....	11
Figure 2: Laser measuring chamber series 1.108 and 1.109.....	12
Figure 3: Screenshot of the Grimm calibration software during a running calibration with one mother unit and three candidates (in this example: Grimm Environmental dust monitors with 31 channels).....	14
Figure 4: Before calibration: Simultaneously measured particle number concentration for all 31 size channels of the candidate (red) and the mother unit (blue) vs. time. ....	15
Figure 5: After calibration: Simultaneously measured particle number concentration for all 31 size channels of the candidate (red) and the mother unit (blue) vs. time. ....	15
Figure 6: Recommended accessory for model 1.108 and 1.109.....	16
Figure 7: Pneumatics scheme for models 1.108 and 1.109.....	20
Figure 8: Control elements on the front panel of models 1.108 and 1.109.....	21
Figure 9: Control elements on the rear panel of models 1.108 and 1.109.....	22
Figure 10: Inserting the data storage card .....	23
Figure 11: keypad at 1.108 and 1.109 with 10 functional keys and loudspeaker for acoustical warnings, mounted behind the keypad (alarm).....	25
Figure 12: PIN configuration of the analog input .....	32
Figure 13: Function principle of the isokinetic sampling probe .....	69
Figure 14: Installation of the sampling probe, a) sampling probe, b) lucent tube, c) sample air refeeding .....	69
Figure 15: Weather protection housing (165) with dryer, mixer electronics and sampling head with integrated annular gap mixer. ....	74
Figure 16: Inhalable, thoracic and alveolic concentration in percent of all airborne particles, according to EN 481:1993, page 5, workplace atmospheres, size fraction definitions. ....	80

## Index of tables

Table 1: Storage times of the data storage cards for firmware version 8.60, model 1.108 .....	24
Table 2: Storage times of the data storage cards for firmware version 12.30, model 1.109 .....	24
Table 3: Brief overview of all key functions .....	31
Table 4: Numerical values of the three mass fractions according to the convention EN 481:1993 and for two environmental mass fractions .....	80

## General

### Annotation

Put hard- and software only after precise study of this manual into operation! The producer is not liable for damages, which are caused through inappropriate initial operation, usage, cleaning, or operating errors.

Many soft- and hardware denominations, which will be mentioned within this manual, are registered trademarks and have to be treated this way. The author's intention is to give you complete and accurate information by this manual. Grimm Aerosol Technik does not guarantee completeness and accuracy of the following available information, which therefore excludes entitlement to damages that result either collateral or directly from the usage of this manual and/ or the usage of the soft- and hardware. Grimm Aerosol Technik moreover is not responsible for damages, which result from patent infringement or abuse of a third's party rights.

Due to continuous improvements and increments differences regarding instruction and illustration of this manual compared to available hard- and software may happen. If so, please ask for the current version of this manual.

All rights reserved. Duplication (copy, print, microfilm, and other media) of any part of this manual without authorization in written form from GRIMM Aerosol Technik is prohibited just as duplication, reproduction, or modification through electronic systems.

Printed in Germany. Copy Right © 2010 by GRIMM Aerosol Technik, Ainring

GRIMM Aerosol Technik GmbH & Co. KG  
Dorfstrasse 9  
D-83404 Ainring

Phone: ++49 / 86 54 / 5 78 – 0  
Fax: ++49 / 86 54 / 5 78 – 35  
Email: [service@grimm-aerosol.com](mailto:service@grimm-aerosol.com)  
Homepage: [www.grimm-aerosol.com](http://www.grimm-aerosol.com)

This manual refers to:

Aerosol spectrometer and dust monitor, series 1.108 and 1.109

M\_E\_IAQ\_1108-1109-Spec\_v2p4

### Meaning of the used symbols

In this manual following symbols will be used in order to ease locating important hints, advices, and situations.



This symbol indicates useful hints, which facilitate and optimize your working process.



This symbol indicates potential dangers, which may lead to malfunctions or even damage of the hardware and how those dangers can be avoided.

# 1 Important hints for the customer

## 1.1 Safety regulations

The manufacturer declines any direct or indirect liability if the operator opens the instrument or manipulates the instrument! This instrument is built and tested in accordance with EN-61010 (DIN VDE 0411 T1) to assure proper protection of the electronic material and measurement function of the instruments. All units have left the factory with regard to safeguarding in a perfect condition. In order to keep this state and to guarantee a safe operation, the customer must follow the references and warning notes which are contained in this manual.

If a safe operation is no longer possible, the instrument has to be taken out of operation and to be protected against unintentional operation. A safe operation is not possible anymore,

- if the instrument shows visible harm,
- if the instrument does not work anymore,
- after longer storage under unfavorable conditions,
- after heavy-duty transportation.

If the instrument was stored or transported at low temperatures and an acclimatisation period prior start up of minimum 1 hour is not kept, the internal pump may not even start (due to possible inner condensation). In this case the electronic protection fuse will activate and disconnect the instruments power supply.

The PTFE-filter is located before the internal pump for its protection. For this reason do not operate the measuring devices without a PTFE filter!

## 1.2 Electric Safety

Before the first use of the instrument you need to check whether the main voltage is in the allowed specifications. Operate the dust monitor only with the designated voltage and the original external power supply.

- The Lithium battery (SL-389; 3,6V; 1AH) on the digital circuit board is necessary to the operation of the real-time clock. This battery must not be charged and only changed in an emptied state by an authorised personal. The normal operation period is several years.
- The recharge of the Lithium battery inside the memory card (CR-2016 with 3V and 60mAh or CR-2325 with 3 and 200mAh) is not permitted.
- Fuses built into the instrument may only be changed by trained service personnel

All fuses are to be replaced only by the same type!

Since the instrument has its internal electronic protection, the fuses will react only at a serious fault. Caution!



### 1.3 Laser safety

Caution! Optical laser class 3 B inside!

The instrument may only be opened by GRIMM trained service personnel. During the opening of the laser unit, especially the measuring chamber, a laser radiation of the class 3 B can be released. The direct look into the laser beam or a reflexion can lead to damage of the eyes even at a short exposure time.

You will find references in the EN 60825 (DIN VDE 0837 T1), but also in the corresponding VBG 93 "Laser radiation" prevention regulation for possible accidental exposure!



All stickers shown are on the bottom of the instrument and warn the operator for laser light radiation in case the covers of the instrument have been dismantled!

Laser class 1 in closed state of the measurement unit! Laser of class 1 are not dangerous and safe for eyes even in case of malfunction due to manipulation or usage of optical additives (e.g. binocular, microscope etc.)

- The glass fuses built in the instrument (Pico fuse 2A, quick-type, and switching capacity 300A /32V DC) must only be replaced by trained service staff with the type specified in the circuit documents. Because the devices are secured by electronically excess-current cut-out the fuse will only respond at a severe malfunction.

### 1.4 Transportation

The instrument may be transported only in the original packing and in the switched off mode. The aerosol inlet and output have to be closed with provided covers.

*We reserve the right to change or improve the instruments described in this manual without previous announcement, simply in accordance to the technical progress. Therefore insignificant deviations between the descriptions in this instruction and your measuring instrument are possible.*

## 2 Model 1.108 and 1.109

### 2.1 Particle measurement with Grimm's Dual-Technology

The dust aerosol spectrometer and dust monitors model 1.108 and 1.109 are compact portable devices which have been built for continuous measurement of airborne particles as well as for measuring the particle count distribution. They possess an integrated gravimetric filter on which all particles are collected after the optical measurement and thus are available for further analysis. This "Dual-Technology" is unique and patent-registered by Grimm Aerosol Technik.

The data can be displayed as **particle concentration** in the unit particle/liter and also as **mass concentration** in the unit  $\mu\text{g}/\text{m}^3$ . By means of the Grimm Windows Software additionally different **dust mass fractions** can be displayed as well as the calculated **particle surface area**. The standardized dust mass fraction is in terms of **occupational health** respirable, thoracic and alveolic according to EN 481. A second dust mass fraction is named **immission** PM10, PM2.5 and PM1. These are provided for comparisons of indoor and outdoor measurements, but are not in compliance with US EPA or European approval for equivalent measurements EN 12341. The measuring principle of the model 1.108 and 1.109 is the light scattering of single particles with a semiconductor laser as light source. Inside the measuring cell the scattering light is being led directly and via a mirror with a wide opening angle onto the detector (see figure 1 and 2). The detector is positioned in the right angle to the incident laser beam. This setup of the detector is denominated as 90° scattering light detection. This optical alignment increases the scattering light collected by the detector and optimizes the signal-to-noise ratio. Therefore even very small particles down to 0.25  $\mu\text{m}$  respectively 0.3  $\mu\text{m}$  can be detected. The optical setup moreover abrades the MIE scattering undulations caused by monochromatic illumination as it is typical for laser light scattering spectrometers and therefore enables a definite particle sizing. If a particle crosses the laser beam, it creates a light pulse. The signal of the detector diode will be classified into different size channels after accordant amplification. Model 1.108 possesses 15 size channels, whereas the model 1.109 is in possession of 31 size channels. This way the particle size distribution can be measured which provides the basis for the calculation of the dust mass. That is why these devices are suitable for a variety of applications like for instance the compilation of occupational health data, dust analysis, inhalation toxicology, aerosol research, or atmospheric research.

The sample air is sucked through the measuring cell and a gravimetric filter by means of an internal volume flow controlled pump. This filter serves as a dust collector and can be used for gravimetric control of the optical gained measurement results. The pump also conveys the rinsing air, which is gained out of the pump's exhaust air via a zero filter and being held constant by a rinsing air control. The rinsing air protects the laser optics just as other components of the optical measuring cell from pollution and serves during the self-test as particle-free reference air.

At the beginning of every measurement the device makes a self-test. Here all optical, pneumatical, and electrical components are being checked. The self-test lasts about 30 seconds. Afterwards the actual measurement starts and the LCD-display shows continuously every six seconds the data. This enables real-time measurements of the dust concentration. At the same time all measuring results will be transmitted in certain, adjustable storage intervals to the storage card if one was inserted into the device. Via the built-in RS-232 interface data can be transmitted to an external PC or printer. Data output can happen in intervals from 6 seconds up to 60 minutes. With online PC connection even intervals of 3, 2, or 1 seconds are possible.

## 2.2 Measuring principle

The sample air is led directly into the measuring cell via the aerosol inlet or other custom-designed air inlets, e.g. for high wind speeds or overpressure. The particles in the sample air are being detected by light scattering inside the measuring cell. The scattering light pulse of every single particle is being counted and the intensity of its scattering light signal classified to a certain particle size. The measuring principle is schematically shown in figure 1.

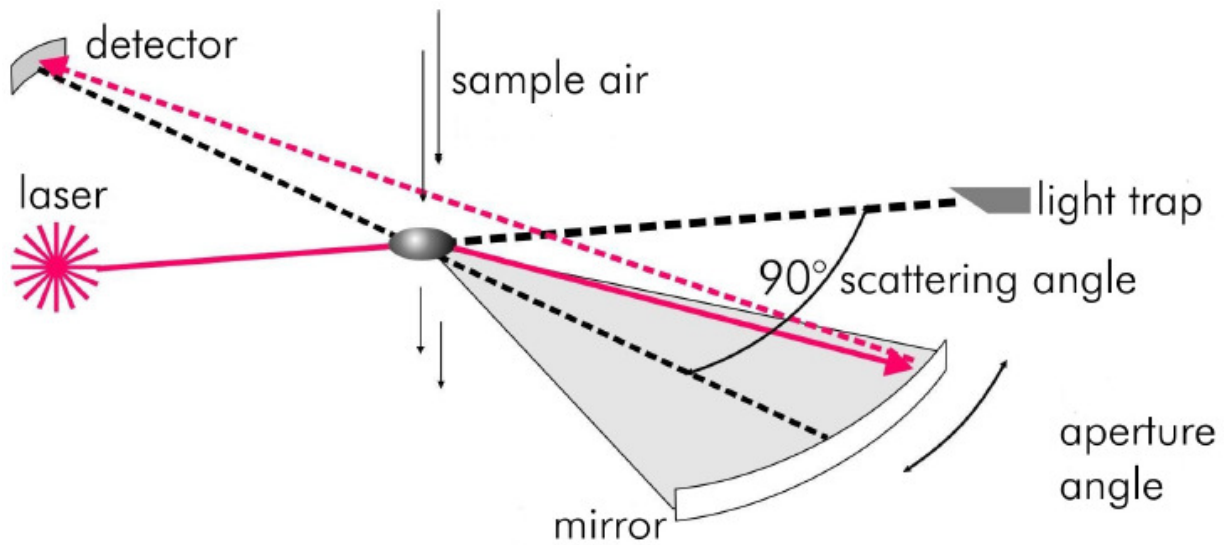

Figure 1: Measuring principle series 1.108 and 1.109

All Grimm laser aerosol spectrometers and dust monitors use a laser diode as light source. The wavelength is different within the model series and is for model 1.108 in infrared range at 780 nm and for model 1.109 in visible range at 655 nm. The laser diode can be operated in a so-called Multiplex Mode, i.e. the intensity of the laser beam is being modulated. This way particles can be detected over a very wide size range from 0.3  $\mu\text{m}$  up to 20  $\mu\text{m}$  (model 1.108) respectively 0.25  $\mu\text{m}$  up to 32  $\mu\text{m}$  (model 1.109). The laser beam is focused to a flat elliptical strip by means of illumination optics. Inside the focus the laser beam lights a small measuring volume evenly and subsequently is being led into a light trap. The sample air is focused aerodynamically and then led as particle flow through the inner area of the measuring volume. When doing environmental measurements, the particle concentration of the sample air is normally so low, that statistically seen only one particle is in the measuring volume. Measuring at particle sources, technical particulate matters, or working places, very high particle concentrations can appear which require a previous dilution of the sample air. Due to the fact that the entire sampling volume of 1.2 liter/minute is analyzed, all Grimm aerosol spectrometers reach a very good counting statistic. The scattering light emitted by every particle is being detected by a second optics under a scattering angle of 90° and then directed onto a receiver diode via a wide-angle mirror. The signal of the detector will be classified into size channels after amplification subject to its intensity. Figure 2 shows the assembly of the laser-measuring chamber. The sample air duct occurs perpendicular to the perspective into the measuring volume.

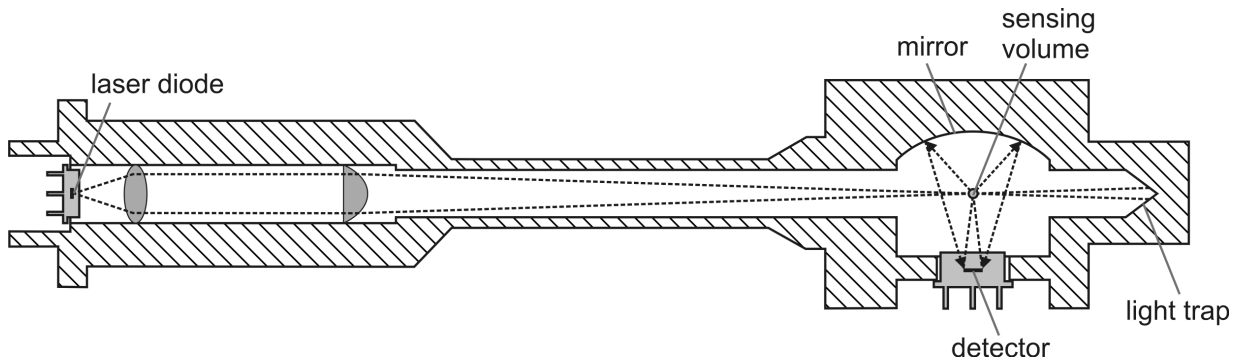

Figure 2: Laser measuring chamber series 1.108 and 1.109

The count rate results from the number of particles divided by volume flow rate. The particle size is proportional to the intensity of the detected scattering light signal whereas the scattering light intensity is also being influenced by the particles refractive index, particle shape, and orientation of the particle within the measuring volume. Positioning the detector into a 90° direction enables minimizing the influence of the aerosol particles' refractive index for determining the particle size. The opening angle of the detector optics was chosen in a way so that an ambiguousness of the scattering light intensity due to MIE scattering undulations caused by monochromatic illumination is being compensated. Thus a distinct detection of the particle size in sufficient narrow size classes is possible. Model 1.109 provides 31 size channels, model 1.108 offers 15. By detection of the particle concentration and particle size, the size distribution of the aerosol particles can be determined which in turn is the basis of the evaluation of the particle mass. Within measuring mode "particle mass" an additional size channel is arithmetically adjoined below the smallest size channel. So model 1.108 outputs within mass mode 16 size channels and model 1.109 analogical 32 size channels. The additional size channel is primarily useful when calculating the standardized mass fractions and leads to an improved accuracy measuring fine aerosols.

For a precise and reproducible particle counting and particle sizing the accurate sampling volume of 1.2 liter/minute is absolutely fundamental. The sampling volume affects the conversion of the raw counts in the actual sampling volume in the selected unit, like liter or m<sup>3</sup> and secondly the particles speed in the optical chamber, which must be in the given tolerance range for a correct particle sizing. That's why the sampling volume at the Grimm Aerosol Spectrometer Model 1.108 is controlled continuously.

## 2.3 Calibration

The particle size detection is calibrated with traceable NIST-certified (National Institute of Standards and Technology) mono disperse latex. The dust mass calculation is being calibrated with dolomite dust compared to a reference device. The instrument will be delivered with a certificate of calibration!



The condition of the spectrometer should be checked annually. Therefore the device has to be sent to the manufacturer where it will be inspected and calibrated by means of a reference device. Alternatively the customer him/herself can do the calibration. Therefore a calibration tower and a reference device are necessary. In order to be able to handle this calibration tower in a correct way, two specific trainings are preliminary! The reference device itself has to be inspected and then certified annually by the manufacturer using mono disperse latex.

How does Grimm Aerosol Technik calibrate?

The calibration of aerosol spectrometers is done by each manufacturer in a different way. Such a method can be denominated as "house-standard" – Why? Because there is no worldwide standard for calibration of aerosol spectrometers, but every manufacturer is supposed to use the standard aerosol particles for size calibration (poly-styrene latex, PSL). The Grimm "calibration-house-standard" is based upon a comparison between a "mother device" calibrated with PSL and a "candidate".

What is a Grimm "mother device"?

For the mother device there was a certain calibration response curve calculated containing all relevant parameters of the aerosol spectrometer (laser wave length, position of the detector, opening angle of the detector, PSL refractive index  $m = 1,60 +i0$ , etc.). Hereupon the mother device will be „fed" with different mono-disperse PSL samples and so validates the particle size measurement for this standard material. The first Grimm mother device, sort of "grandmother", moreover was being compared to a reference device, viz. the laser aerosol spectrometer model LAS-X by PMS, Boulder, Colorado. By this procedure we ensure the correct particle size measurement in the specified channel, e.g. for model 1.108 15 and for model 1.109 31 channels.

Calibration, physics background

Particle sizing is calibrated with NIST traceable Poly-Styrene Latex (PSL), Duke Scientific. So we measure optical latex equivalent diameters. The size channels are related to electronic thresholds. A single particle passing the laser beam will scatter the incident laser light. This scattered light is collected by a mirror in a given angle and focused to the detector. The photons collected by the detector will give a "raw-signal" which will be amplified and classified in a particle size channel. So number concentration and size of the aerosol particles can be measured.

Grimm Calibration procedure

The calibration between a candidate and the mother unit is done by use of a "Grimm Calibration Tower" that is fully computer-controlled and -automated and poly disperse dolomite dust as a standard aerosol. Why dolomite dust? Dolomite dust is cheap, anoxic, not hygroscopic, poly disperse and very stable during storage. The dolomite dust covers the entire sizing range for all Grimm spectrometer from app.  $0.2\mu\text{m}$  up to  $>30\mu\text{m}$ . Due to the fact that both the mother unit and the candidate are manufactured identically, the dolomite dust must lead to identical results in both spectrometers. The dolomite dust is injected by a 40msec pulse of particle-free compressed air at the top of the cylindrical calibration tower and dispersed homogeneously over the whole round cross-section. At the bottom of the calibration tower up to three candidates and one mother unit are attached at identical aerosol inlets. A reverse flow of particle-free compressed air from the bottom to the top of the cylindrical tower guaranties a well-defined and reproducibile aerosol particle distribution during the whole calibration procedure.

During the calibration the counts in every single size channel, starting from the biggest, are compared between the mother unit and the candidate simultaneously. The calibration software is able to compare six size channels at the same time. The statistical comparison is based on a mean value calculated by a set of 15 single values. A single value is displayed every 6 seconds. Depending on the measured particle concentration, the calibration software can adjust the electronically thresholds of the candidate.

Threshold lower = more particles in the channel

Threshold higher = less particles in the channel

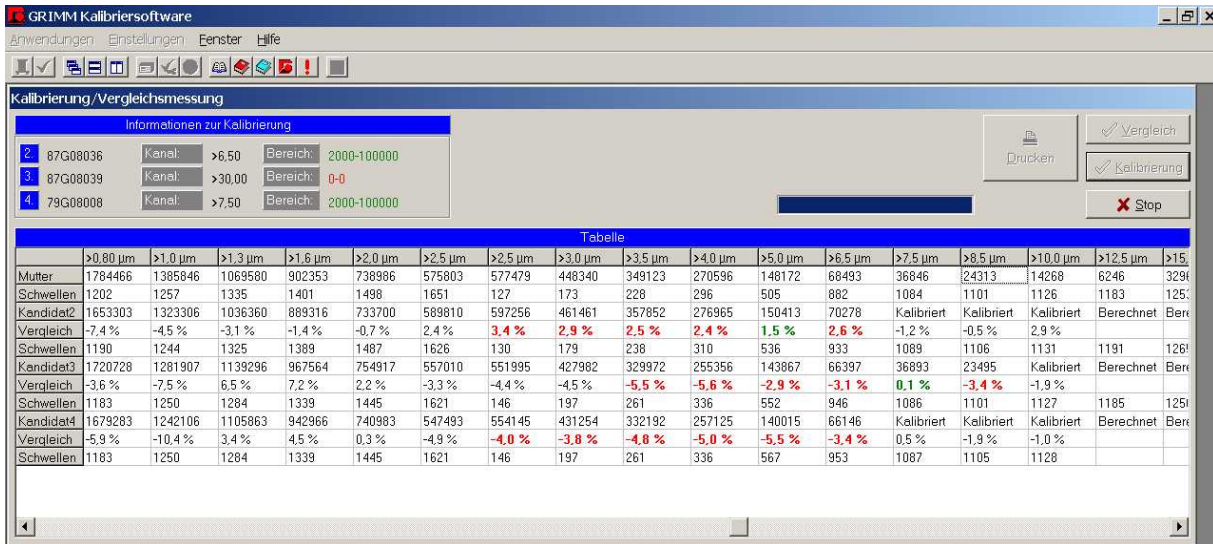

Figure 3: Screenshot of the Grimm calibration software during a running calibration with one mother unit and three candidates (in this example: Grimm Environmental dust monitors with 31 channels).

The columns in the table in Figure 3 show the 31 size channels. The lines in the table in Figure 3 show from top to bottom: the counts of the reference unit, and for each candidate the electronically settings of the threshold, the counts of the candidate and the calculated relative error. To indicate the meaning of the relative errors three different colours are used:

Red values indicate a running calibration of a size channel out of range. Green values mean a running calibration within the range. Black values means, that the relative error is saved for quality assurance, the channel threshold is fixed and the channel is labeled with "Kalibriert" in the software table.

The mean value comparison is repeated approximately 10 times for each size channel, till all readings of the candidate are repeatedly within a given range with a accuracy of ± 2%, compared to the mother unit. The certified accuracy for the mass mode is ± 5%, because of the fact that the particle diameter affects the particle mass by the third power. The calibration software controls all relevant parameters plus the amount of calibration dust, in order to assure that the measured concentrations are above a fixed minimum. All results are stored electronically and are activated in a data bank for quality assurance.

After the tower calibration, a further comparison at indoor conditions is done.

To illustrate the described procedure, the following two screenshots, so called "ramp" from the Grimm calibration software CalSoft, show two examples of a measured particle number concentration of a candidate compared to a reference unit before and after a calibration.

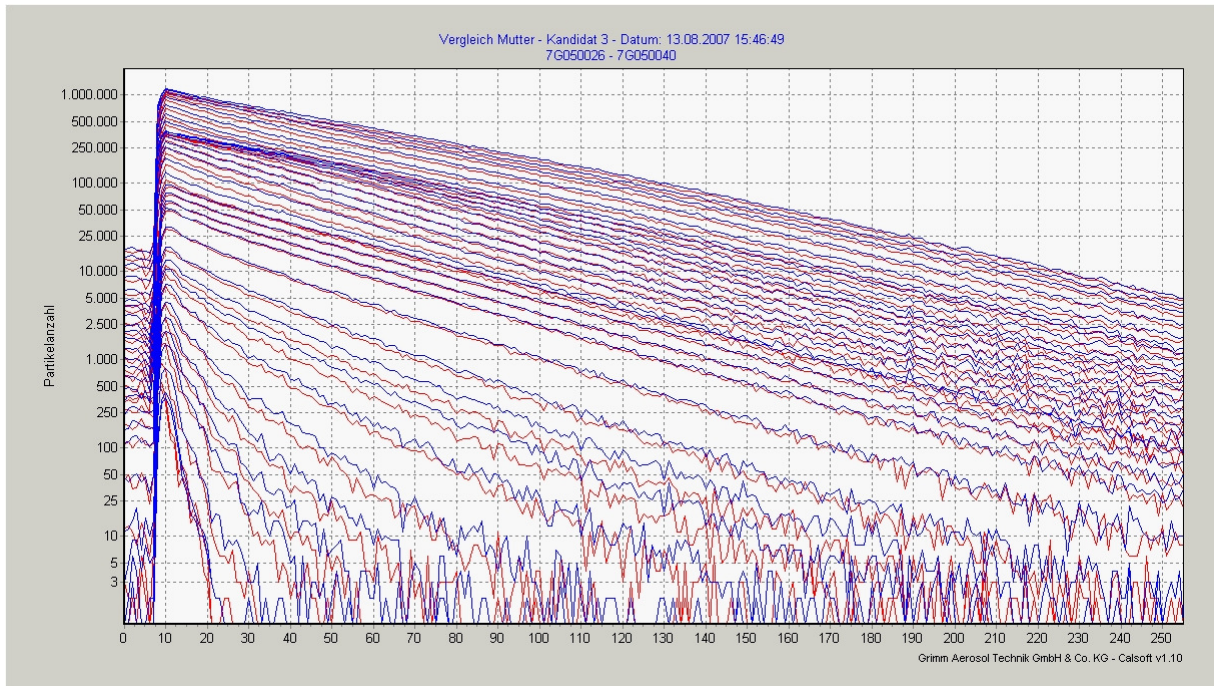

Figure 4: Before calibration: Simultaneously measured particle number concentration for all 31 size channels of the candidate (red) and the mother unit (blue) vs. time.

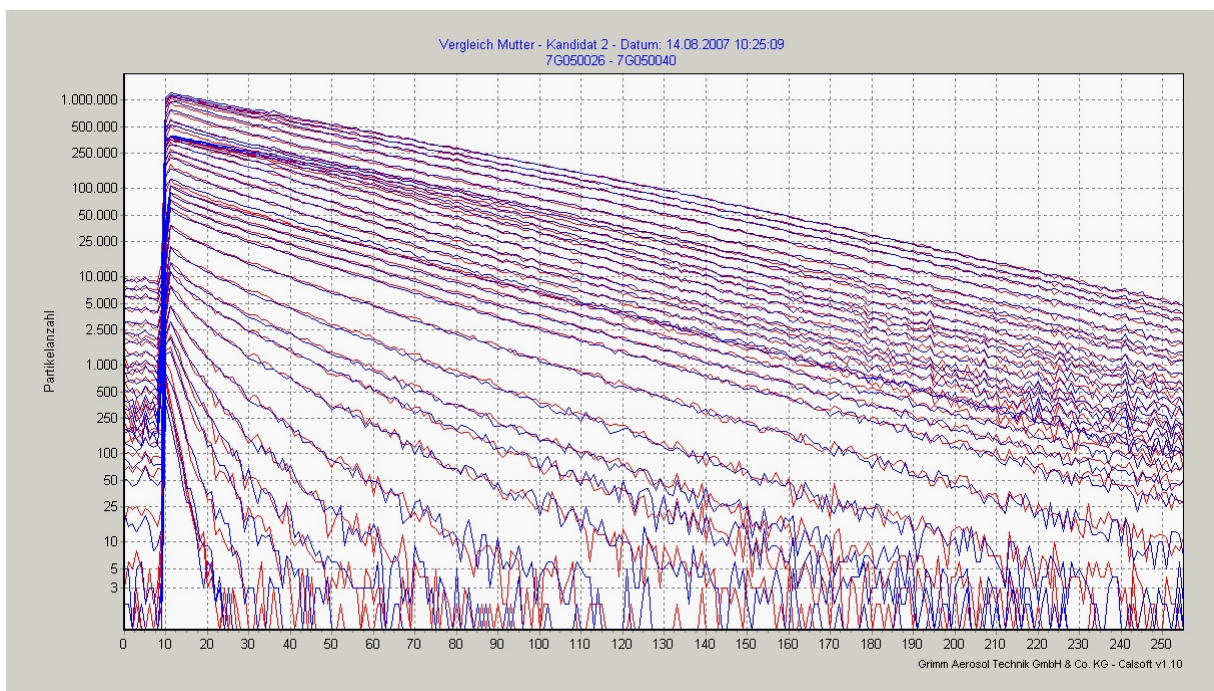

Figure 5: After calibration: Simultaneously measured particle number concentration for all 31 size channels of the candidate (red) and the mother unit (blue) vs. time.

The measurands of both devices in Figure 4 show a very strong variability. The ramps do not run congruent. Figure 5 shows clearly that the measurands between reference device and candidate are almost exactly in accordance to each other. The curves for every size channel are almost congruent.

## 2.4 List of accessory

After unpacking the device please check the scope of delivery with the packing list for completeness. In case of damage or missing components please contact Grimm Aerosol Technik or your local dealer immediately.

### Necessary respectively recommended accessory

Nr. in Figure 6	Product-Nr.	Description
1	1.141	Special Grimm USB-data-cable for RS-232
2	1.112A	Power supply 95-250 VAC, 47-63 Hz
3	1.143E	Special Grimm RS-232 connecting cable
4	1.113A	25 PTFE-filter, 47 mm
5	1.110	Lead battery type LCS 2312 AVBNC, 12V/2,3A for 6-8 hours continuous operation
6	1.111	Radial-symmetric sampling head
7	1.119	Straight sampling tube for hose
8	1.142.A4	Data storage card with 4 MB storage capacity
9	1.177	Windows software (Version 3.30, date 2009)
10	1.148	Mini-filter for 0-test
-	1.144B	PVC carrying case with rigid foamed plastic insert for device and accessory
-	1.118A	User manual in German or English



Figure 6: Recommended accessory for model 1.108 and 1.109



**Additional accessory according to appliance**

1.145A	Black leather carrying bag with shoulder strip
1.147	External acoustic and visual alarm unit
1.149B	Spare part set for 2 <sup>nd</sup> year (includes X803, 1.110, 1.113A, 1.119, 1.148, a.o.)
1.151A	Clean room sampling heads for air speeds 0.5, 1, 2, and 4 m/s
1.152	Isokinetic sampling set for air speeds 2-25 m/sec (4 nozzles)
1.153FH	Sensor for temperature and rel. humidity
1.154	Sensor for temperature, rel. humidity and air velocity (0.3 up to 20 m/s)
1.162	Plug for analogue socket
1.301	Indoor PAH-sensor, measures particle bound PAH concentration as sum signal (needs the 1301 HLX carrier as well)
1.301 HLX	Carrying adapter for model 1301 to combine with aerosol spectrometer 1.108 or 1.109
1.320	NanoCheck, portable nano attachment, measures particle concentration and mean diameter from 25 to 300 nm (needs the 1365 HLX carrier as well)
1.365 HLX	Carrying adapter for model 1320 to combine with aerosol spectrometer 1.108 or 1.109
7.910	Diffuser for sampling inside pressure pipes up to 6 bar

**Source of supply**

Accessory, consumables and spare parts can be ordered at your local dealer or at

GRIMM Aerosol Technik GmbH & Co. KG Dorfstrasse 9 83404 Ainring Tel.: +49 (0) 8654-578-0
---

## 2.5 Technical data

### Nominal rating 1.108 and 1.109

Supply voltage:	18 - 24VDC mains, CLASS II, safety extra low voltage (SELV) (optionally: battery: 12V/2,3Ah, type LC-SA122R3B6 no stand by parallel operation. CLASS III (safety extra-low voltage); (optionally: battery 12/1.9Ah, type LCTA 121R9PG for stand by parallel operation. CLASS III (safety extra-low voltage);
Frequency:	0 Hz
Maximum current:	2.5 A
Application use:	Indoors use. With appropriate accessory for outdoor use also.
Maximum altitude:	1000 m (3300 feet). 2000m (6500 feet) with individual 1108/1109- fow-regulation-setpoint adjustment
Temperature range (operating):	0 to +40 °C, (32 to 104 °F)
Temperature range (storing and transportation):	-20 to +50 °C, (32 to 104 °F)
Max. relative humidity (operating)	r.H. < 95 % (not condensing)
Max. relative humidity (storing and transportation)	r.H < 90 % (not condensing)
Sample air temperature:	0°C to +40 °C, (32°F to 104 °F) < 95% r.H.
Sample air pressure range:	Absolute: 1013hPa +/- 120 hPa, equates up to ca. 1000m ASL Relative: +/- 50 hPa for short-time periods. For continuous operation or differential pressures up to +/-100 hPa the sample air must be looped back to avoid high $\Delta p$ .

### Technical data 1.108 and 1.109

Laser:	Wave length: $\lambda = 655 \text{ nm}$ (1.109) respectively. 780 nm (1.108) Power: $P_{\text{max}} = 40\text{mW}$ $P_{\text{nom}} = 0, 5/30 \text{ mW CW}$ (Multiplex)
Size channels:	Given channel thresholds [ $\mu\text{m}$ ] are valid for a count efficiency ratio of 50% with mono-disperse latex aerosol 31 channels (1.109) 0.25/ 0.28/ 0.3/ 0.35/ 0.4/ 0.45/ 0.5/ 0.58/ 0.65/ 0.7/ 0.8/ 1.0/ 1.3/ 1.6/ 2/ 2.5/ 3/ 3.5/ 4/ 5/ 6.5/ 7.5/ 8.5/ 10/ 12.5/ 15/ 17.5/ 20/ 25/ 30/ 32 15 channels (1.108) 0.3/ 0.4/ 0.5/ 0.65/ 0.8/ 1.0/ 1.6/ 2/ 3/ 4/ 5/ 7.5/ 10/ 15/ 20
Particle concentration:	1 to 2.000.000 particles/liter
Dust mass range:	0.1 to 100.000 $\mu\text{g}/\text{m}^3$ Illustrating the mass distribution an additional channel up to 0.23 $\mu\text{m}$ below the actual measuring range will be extrapolated by adjustment through a lognormal distribution.
Reproducibility:	$\pm 3\%$ over the whole measuring range
Sample flow rate:	1.2 l/min, $\pm 5\%$ constantly through control
Rinsing air flow rate:	0.3 l/min constantly through control. Automatic self-cleaning when switching into stand by mode
Dust collection:	47 mm PTFE filter (without supporting tissue)
Handling:	Via keypad or PC and RS-232 interface using the Windows software

LCD-display:	or HyperTerminal program and control commands 2 x 16 alphanumeric characters, illuminated
Self-test:	Automatically after each start up
Measuring intervals:	Selectable: 6 sec normal (for all channels) or in 1, 2, or 3 seconds intervals selectable for the lower or upper half of all size channels (equates to 16 channels for the 1.109 resp. 8 channels for the 1.108)
Storage interval:	Selectable: 6 sec, 1 min, 5 min, 10 min, 15 min, 30 min, 60 min (for all channels) or 1, 2, or 3 seconds for the lower or upper half of all size channels (equates to 16 channels for the 1.109 respectively. 8 channels for the 1.108)
Communication:	External RS-232 9-pole SUB-D female connector, for communication with external PC, standard-setup: DTE (Pin2: RxD, Pin3: TxD)
Data output LCD-display:	Dust concentrations or particle number concentration as sliding average over a minute or averages with their according sample volume. Alarm values, battery capacity, gravimetric factor, measuring location number, date and time, and values of the optional accessory units (sensors)
Data output:	Via PC and RS-232 interface, also from RS-232 to USB possible
Analogue input:	Cable with 6-pole analog-connector for 3 signals (0-10V), resolution 10 Bit (ca. 10 mV). Display with editable texts and calibration factors.
Data interface:	ASCII: RS-232 (9600 Baud, 8 Bit, no parity, 1 stop-Bit, protocol: Xon/Xoff)
Data storage card:	4 MByte, battery buffered. Following data will be stored next to the measurands: date, time, measuring location number, gravimetric factor, error code, battery capacity, motor current, and the analog voltages of the external sensors (1 to 3)
Sample air:	+4 to +40 °C, (39 to 104 °F) r.H. < 95 % no corrosive or explosive gases
Sample air refeeding:	Yes, exit for sample air exhaust on the backside of the device
Dimensions L x W x H	24 x 13 x 7 [cm] (9,45 x 5.12 x 2.76 [inches])
Weight:	1.7 kg (3.7lb) + 0.7kg (1.5lb) lead battery
Memory function:	The function once selected in the last standby mode will automatically boot up again once the instrument is removed from the standby mode or powered up again. The display mode remains as previously set. Alarm-values, calculated filter-weight and sample flow remain stored. Should a power failure occur during a measurement cycle, all of the functions pre-selected by the user and any of the recorded values will be stored. Once power is restored, pre-selected measurement cycle will automatically be continued.

## 2.6 Pneumatics

The figure below shows the pneumatics of the models 1.108 and 1.109. The sample volume flow rate of 1.2l/min is controlled, as well as the internal rinsing air circuit. The used filters are optimized on a low-pressure drop, in order to ensure a power supply via lead battery as long as possible.

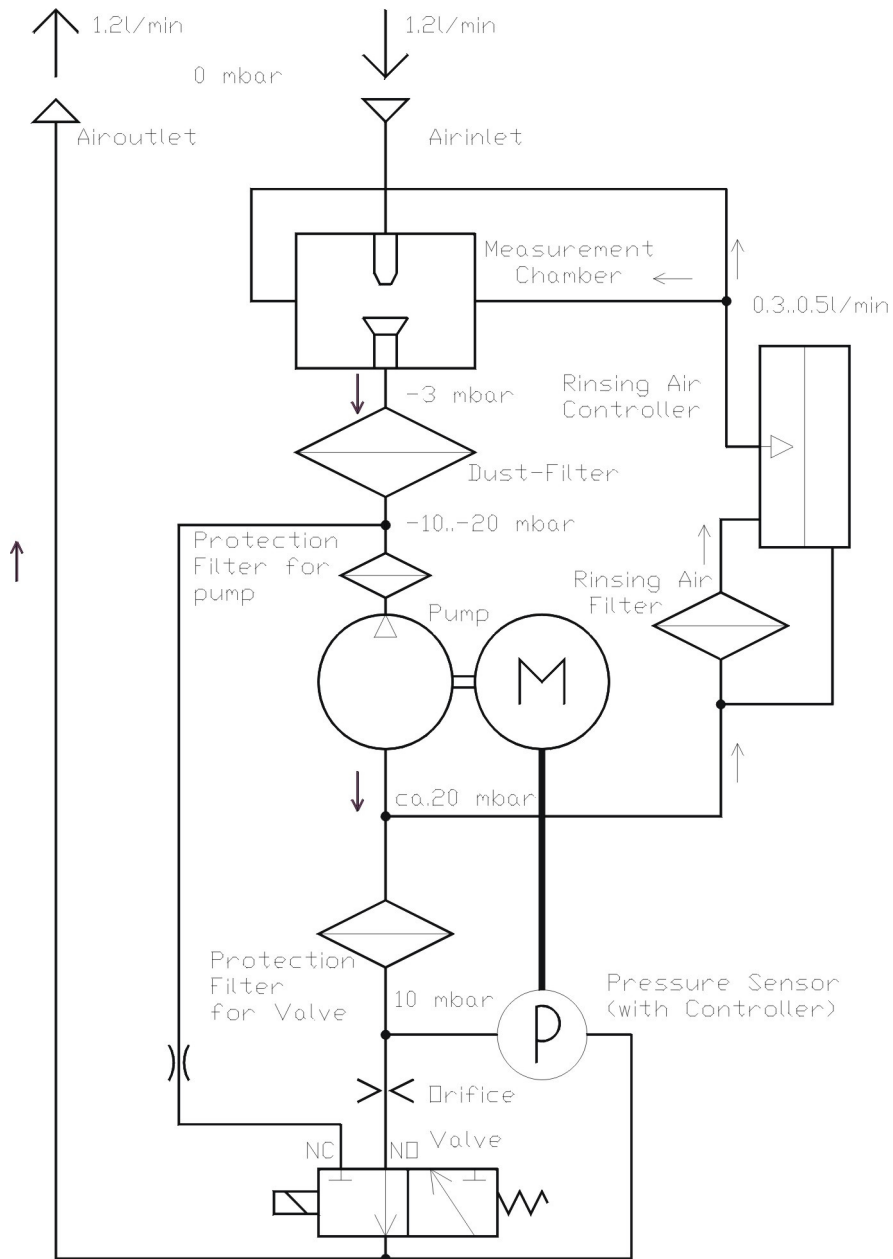

Figure 7: Pneumatics scheme for models 1.108 and 1.109

Within operational mode a rinsing air circuit flows through the optical chamber in order to protect the optical components. The optical chamber can be flushed completely with particle-free air. This is done during the self-test to inspect the optical components and during the measurement for minimizing contamination.

### 3 Control elements



Read this manual carefully BEFORE taking the device into operation!

Please inspect every single part of the measurement unit after unpacking. If you expect that the device cannot be run safely anymore put it out of operation and ensure it cannot be run accidentally anymore.

Expect a not safe operation, if

- the device shows apparent damages,
- the device does not work anymore,
- the device was being long-term stored under inappropriate conditions,
- the device suffered under heavy-duty transportation.

The following chapter explicates the different control elements of your dust monitor. The figures and elucidation are valid both for model 1.108 and 1.109.

Handling this device you distinguish between **standby mode** and **operational mode**. Within stand-by mode all settings can be requested and changed. Within operational mode the actual measurement takes place and all settings are fixed and cannot be altered.



Figure 8: Control elements on the front panel of models 1.108 and 1.109

- 1 LCD- display
- 2 Slot for data storage card
- 3 Keypad
- 4 Sample inlet
- 5 Analog input
- 6 Connection for mains adapter
- 7 RS-232 interface



Figure 9: Control elements on the rear panel of models 1.108 and 1.109

- 8 Filter chamber with bayonet lock
- 9 PTFE-filter, 47 mm
- 10 Warning notice for laser
- 11 Calibration label
- 12 Device designation and serial number
- 13 Sample outlet with end cap
- 14 Locking feature for battery case (lateral) and lead storage battery

### 3.1 LCD-Display



The optical display of the device consists of a LCD (Liquid-Crystal-Display) with 2 x 16 digits. The display indicates the results and optional sensor values. In addition all settings are displayed like date, time, location, battery status, storage interval, and all important status messages.

### 3.2 Data storage card

Both model 1.108 and model 1.109 are equipped with an internal 80 kByte memory. In order to be able to store larger amounts of data, like as measurement rows with a high temporal resolution without a connected PC, we recommend using a data storage card. Please mind: Only PCMCIA SRAM data storage cards can be used. The data will be stored as FIFO-method (First in First out), i.e. stored in a circular buffer so that the oldest values are going to be overwritten when having a full storage card. The maximum storage times depend on the set storage interval and the storage cards' capacity.



The data storage card has to be installed before beginning the measurement. Moreover the storage card has to be initialized respectively deleted previous to first-time application inside a device.

### Starting up and initiating the data storage card

Insert the storage card with arrow facing up into the slot at the front panel of the dust monitor beneath the display until you hear a gentle click. A correct inserted storage card protrudes from the device about 1 cm.



Figure 10: Inserting the data storage card

Is the storage card inserted when switching on the device or is it being inserted within stand-by mode and subsequently accepted, the LCD shows for about 3 seconds card size and version. Afterwards the interval and free storage time will be displayed. With the keys "+" and "-" the data storage interval can be changed during this indication and the free storage times refresh. With an inserted and installed data storage card all measured values will automatically be saved on the storage card.



The device will only accept a data storage card if all data have been deleted or if the card already has been used inside the same device without changing the number or kind of sensors. A not accepted data storage card does not show free storage space. It is not possible to use a data storage card from an other device if this card is not empty. Already existing data from an other device with a different serial number have to be deleted, before new data from the actual device can be stored on this card.

The storage card can be deleted in two different ways. On the one hand with the adequate key combination via the key pad, see chapter 3.3 Key functions in the standby mode, or on the other hand via the Windows software, or an adequate control command using the HyperTerminal, see RS-232 in chapter 5.3.

The measurement does not start if the storage card is not accepted. Please check if the write protection of the data storage card is being activated. The write protection can be activated respectively deactivated with slider next to the cards' battery case.

If no data storage card is being used the LCD shows after switching on the device:

**„NO MEMOCARD“**

Starting a measurement and additional warning signal (beep-tone) resounds.

**Data preservation and storage times**

A buffer battery preserves the data on the storage card. If the storage card is inserted inside the device, the power supply happens via the device. Before changing the battery please read out all the data otherwise data loss might happen.

Having the message:

**„PLEASE REPLACE MEMOCARD“**

means that the battery of the storage card has to be changed.

There are data storage cards with various storage capacity, beginning at 256 KB up to 4 MB. The storage interval can be selected stepwise. Transcending the stated storage time leads to overwriting of the oldest values. The card remains ready-to-operate.

*Table 1: Storage times of the data storage cards for firmware version 8.60, model 1.108*

INTERVAL	1min	5min	10min	15min	30min	60min	6sec	3sec	2sec	1sec
<b>INTERN (80 Kbyte)</b>	21h 4min	4d 12h	9d 0h	13d 13h	27d 2h	54d 4h	2h 10min	1h 5min	43min	21min
<b>256 Kbyte</b>	2d 21h	14d 10h	28d 21h	43d 8h	86d 16h	173d 8h	6h 56min	3h 28min	2h 18min	1h 9min
<b>512 Kbyte</b>	5d 18h	28d 21h	57d 18h	86d 16h	173d 8h	346d 16h	13h 52min	6h 56min	4h 37min	2h 18min
<b>1 Mbyte</b>	11d 13h	57d 18h	115d 13h	173d 8h	346d 16h	1Y 328d	1d 3h	13h 52min	9h 14min	4h 37min
<b>4 Mbyte</b>	46d 5h	231d 2h	1Y 97d	1Y 328d	3Y 291d	7Y 218d	4d 15h	2d 7h	1d 13h	18h 29min

*Table 2: Storage times of the data storage cards for firmware version 12.30, model 1.109*

INTERVAL	1min	5min	10min	15min	30min	60min	6sec	3sec	2sec	1sec
<b>INTERN (80 Kbyte)</b>	12h	2d 13h	5d 2h	7d 15h	15d 7h	30d 15h	1h 12min	36min	24min	12min
<b>256 Kbyte</b>	1d 15h	8d 4h	16d 8h	24d 12h	49d 0h	98d 0h	3h 56min	1h 58min	1h 18min	39 min
<b>512 Kbyte</b>	3d 6h	16d 8h	32d 16h	65d 8h	98d 0h	196d 0h	7h 52min	3h 56min	2h 37min	1h 18min
<b>1 Mbyte</b>	6d 12h	32d 16h	65d 8h	98d 0h	196d 0h	1y 27d	15h 44min	7h 52min	5h 14min	2h 37min
<b>4 Mbyte</b>	26d 3h	130d 16h	261d 8h	1Y 27d	2Y 54d	4Y 108d	2d 15h	1d 7h	20h 59min	10h 29min

Some more hints:

- The storage card should be changed in standby mode only, otherwise data loss might happen.
- If the storage card has not been inserted before beginning a new measurement, the device has to be switched back into stand-by mode by pressing the “Standby” key before you again insert the data storage card.
- The average life expectancy of the battery inside a 1 MB data storage card is more than a year. If the storage card is not used for a longer period of time the battery should be taken out of the card.
- The storage card can be read out only via the GRIMM aerosol spectrometer or the GRIMM external card reader model 1.155A. It cannot be read out via a PC slot for PCSI cards!



### 3.3 Keypad and key functions



The instrument comes with 10 functional keys. With the **[ON/OFF]** key the instrument is switched on and off. This key has a fail-safe mechanism to assist in preventing the instrument from being unintentionally turned off. In order to switch off the instrument, the ON/OFF key must be pressed for approximately one second till a beep will sound. A restart should be done after 5 seconds at the earliest.

The instrument should always be switched over to the stand-by mode before switching off the unit. Failure to do so could cause the loss of data from the data memory card. In the event that the instrument is switched off due to a power failure, the unit will automatically restart measurements with the user-selected parameters once power is restored. The instrument will switch directly to the operational mode without asking for "filter-exchange" information and will calculate the mean values included in the previous measurement.

If the instrument ends up in an undefined status, e.g. due to a heavy external failure, which disables the control via the keypad, the instrument has to be shut down by removing the battery or the mains supply respectively. After inserting the battery or after connected mains adapter the instrument will switch on automatically. Due to this mechanism a measurement will be continued independently after a power cut.

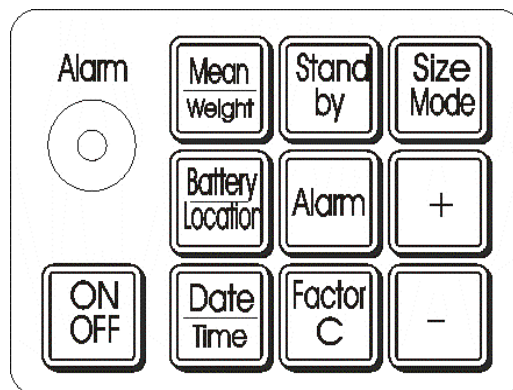

Figure 11: keypad at 1.108 and 1.109 with 10 functional keys and loudspeaker for acoustical warnings, mounted behind the keypad (alarm).

The key functions partly differ in run mode and standby mode. All functions will be explained on the following pages in detail. To change the settings at the instrument the respective key has to be pressed and hold, and then the changes can be input by using the **[+]** and **[-]** keys. All changes entered via the keypad will be confirmed by a "beep" signal.

### Key functions in the standby mode

The settings of the aerosol spectrometer can be changed in the standby mode. by use of the [+] and [-] keys.

### Mean values and calculated filter weight



The options for pressing the **[Mean/Weight]** key solitary are the same in the operational mode. Pressing the **[Mean/Weight]** key will display the mean value in mass or counts. The selected channels are hereby underlined. The mean calculation takes all measurements into account since the instrument was powered up or the mean value calculation was reset to zero.

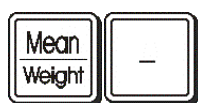

When pressing **[Mean/Weight]** and holding the **[-]** key for 5 sec, the mean value will be reset to zero. Also the sample air volume will be reset to zero.

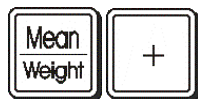

When pressing **[Mean/Weight]** and holding the **[+]** key for 5 sec the calculated filter weight and the corresponding sample air volume will be displayed. This value is essential for the determination of the C-factor for gravimetric validation.

### Clear memory card and formatting the data storage card



When pressing **[Mean/Weight]** and the **[Factor C]** key simultaneously, the message “**clear memory card, are you sure?**” will show up. Confirming this question by pressing the key **[+]** will clear all data on the data storage card and format the card. If no data storage card is in the instrument, the message “clear memory, are you sure?” will show up. The erasure is the same procedure and will clear the 80 Kbytes internal memory.

This key combination also lets you format a new data storage card previous to first time operation or if you want to use a data storage card which has been used in another device before.

### Starting a new measurement



Leave the stand-by mode and start a new measurement by pressing the **[Stand-by]** key.

### Setting the measurement mode and choice of the displayed size channels



Holding the key **[Size Mode]** and pressing additionally the key **[+]** or **[-]** lets you change the measurement mode, either particle mass or particle concentration. The LCD display shows on the right side the accordant unit  $\mu\text{g}/\text{m}^3$  or particle per liter as “/l”.



Decisive for the measurement mode and the change of the measurement mode is the setting in the upper line of the LCD display. Leaving the size range by pressing the key **[+]** or **[-]** the measurement mode changes.

Example 1: The display of the 1.108 shows in the mass mode  $>20\mu\text{m} \dots \mu\text{g}/\text{m}^3$  in the upper line. Pressing [+] again and the measurement mode will change to particle concentration, indicated by  $>0.3\mu\text{m} \dots /\text{l}$ .

Example 2: The display of the 1.109 shows  $>0.25\mu\text{m} \dots /\text{l}$  in the concentration mode, pressing [-] will switch to mass mode, indicated by  $>32\mu\text{m} \dots \mu\text{g}/\text{m}^3$ . The size channel that is chosen in the lower line of the LCD has no influence on the choice of the measurement mode. It simply shows the data of a second channel within operational mode.



Please notice that the data sent via the RS-232 interface and the data stored onto the storage card are the same type as the set displayed operation type. That means either dust mass or particle concentration can be displayed and stored!

### Displaying the analog values



Pressing only the key **[Size/Mode]** longer than three seconds or pressing additionally the key **[Date/Time]**, the values of the analog input values and time will be displayed. This remains set until pressing any other key.

### Requesting the battery capacity and measurement location number

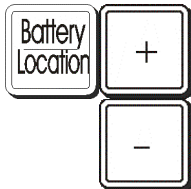

By pressing the **[Battery/Location]** key the current battery capacity as percentage as well as the set measurement location number will be displayed. When operating with a mains adapter, always 130% are displayed. At a fresh charged battery values above 100% are possible. Pressing and holding the key **[Battery/Location]** the measurement location number can be altered by means of the keys **[+]** or **[-]**. The measurement location number is an additional differentiation of various measurements and can be set between 1 and 99.



When reading out the data storage card via the Windows software, the datasets can be chosen individually according to their measurement location number, which shortens and simplifies the data transmission.

### Changing the alarm thresholds, necessity of a diluter at coincidence

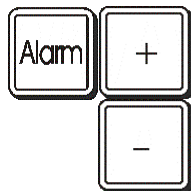

Simultaneous pressing of the keys **[Alarm]** and **[+]** or **[-]** changes the alarm thresholds. A value of 0 deactivates the alarm function. A value bigger than 0 activates the alarm. The alarm value always refers to the size channel in the upper line of the LCD and the set operational mode (mass or particle concentration).

	<p>An alarm value of 2 000 000 /l for the lowermost size channel (&gt;0,3µm for 1.108, respectively &gt;0,25µm for 1.109) shows within operation mode particle concentration a transgression of the measurable total concentration (coincidence). In this case a diluter is necessary.</p>
---	--

**Setting the storage interval**



After inserting the data storage card the LCD shows the storage card's capacity as well as the spare storage time. During this display the storage interval can be changed with the keys **[+]** or **[-]**. By short lifting of the storage card and reinserting, the LCD again shows the storage card's capacity, but now with the new information of the spare storage time.

**Setting date and time**

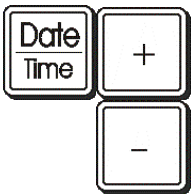

Short pressing: Displaying date and time.  
 Longer pressing: Setting date and time.  
 The location of the blinking cursor can be altered by pressing **[+]** or **[-]**. Pressing **[Date/Time]** again transfers the cursor. Pressing no key for about 3 seconds, the device switches back into stand-by mode. Changing the minutes zeroes the seconds.

**Changing the gravimetric factor**

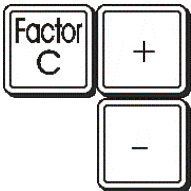

Simultaneous pressing of the keys **[Factor C]** and **[+]** or **[-]** lets you alter the gravimetric factor in intervals of 0.05 between 0.1 and 9.9.

	<p>The C-factor will be taken into consideration when displaying the dust mass on the LCD. Displaying the dust mass via HyperTerminal they are always related to a C-factor of 1. The C-factor will be separately given on seventh position in the P-line (GF for gravimetric factor). When operating via the Windows software the C-factor has to be set in the menu "Options" under "Dust Monitor" respectively "Measurement Locations".</p>
---	--

**Printout of the storage card data**



Within stand-by mode data can be transmitted to an external printer via the RS-232 interface by pressing **[Mean/Weight]** and **[Alarm]** at the same time. Only datasets that are concordant with the present measurement location number will be sent.

## Key functions in the operational mode



In the operational mode, that is to say during active measurement, all settings are fix and can only be read by pressing the respective functional keys.

### Mean values and calculated filter weight



The options for pressing the **[Mean/Weight]** key solitary, are the same in the standby mode. Pressing the Mean/Weight key will display the mean value in mass or counts. The selected channels hereby are underlined. The mean calculation takes into account all measurements since the instrument was powered up or the mean value calculation was reset to zero.



Pressing **[Mean/Weight]** and holding the **[-]** key for 5 sec will reset the mean value (mass or counts and sample volume), so the next mean value of the following measurement will be calculated without taking the previous ones into consideration.



Same as in the standby mode. By pressing **[Mean/Weight]** and holding the **[+]** key for 5 sec, the calculated weight on the filter and the corresponding sampled volume will be displayed. The estimated dust weight indicates whether the collected dust mass is sufficient to be determined within a suitable tolerance with the available microbalance.

The dust weight calculation takes all measurements into account (mass and counts) since the last filter change. It must be pointed out that the C-factor is not taken into account for calculating the estimated dust weight.

### Stop a measurement



Pressing this key interrupts the measurement and switches the instrument to the standby mode. Pressing this key again re-activates the measurement process.

### Hold the actual value on the LCD-Display



Typically the values are refreshed all 6 sec. and shown on the display. The actual value is holding on the LCD-display as long as the **[Size/Mode]** key is pressed while the measurement continues in the background. The operational mode can be changed in standby only.

### Indicate the battery capacity and location number



Like in standby mode. By pressing the **[Battery/Location]** key the current battery capacity as well as the set measurement location number will be displayed.

### Requesting the alarm thresholds



By pressing this key the current alarm value can be requested. The alarm value always refers to the size channel, which is set in the upper line of the display. Setting the alarm value to 0 this function is not active.

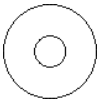

Pressing this key when using the weather protection housing shows the threshold of the relative humidity when the mixer operation shall be activated.

Behind these two concentric circles the speaker for the acoustic alarm signals is located.

### Requesting the analog input values



Pressing this key **[+]** switches on the cyclic display of the analog input values of the hooked up sensors. With the key **[-]** the cyclic display can be switched off. The sensor values appear in the upper line of the LCD alternating with the measurands of the selected operational mode.

### Requesting date and time



Pressing this key shows date and time.

### Requesting the gravimetric factor



The set gravimetric factor will be shown when pressing this key. This also suppresses the cyclic display of the analog input values.

### Alarm and error messages

A warning signal resounds and a message appears on the LCD display when:

- Exceeding the set alarm threshold
- Device errors (e.g. too low battery capacity, high pump motor current, etc.)

The errors will also be stored with the data sets onto the storage card and output via the RS-232.

### Brief overview of all key functions

Certain key functions are activated just in the operational mode or in the standby mode. During the question filter change some additional functions are active. The [and] in the "key"-column means that two keys are to be pressed simultaneously. By holding the functional key, the settings are displayed longer.

Table 3: Brief overview of all key functions

Key	Function-display	Operation mode	Standby mode
[ON/OFF]	Powers up and powers down the instrument with battery or power supply.		
[Mean/Weight]	Displays the mean value (mass or counts and sample volume) for the two selected size channels accumulated of all measurements since the instrument was powered up or the mean value was reset.	X	X
<i>hold</i> [Mean/Weight] and [+]	As for [Mean/Weight], described above. In addition, the calculated dust weight collected on the filter and the corresponding sample volume will be displayed.	X	X
[Mean/Weight] and [-]	Resets the mean value (mass or counts and sample volume), so the next mean value of the following measurement will be calculated, without taking the previous ones into consideration. Powering down the instrument will also reset these average values.		X
[Standby]	Stops the active measurement.	X	
[Standby]	Starts a new measurement.		X
[+] or [-]	Changing the storage interval: After putting in the storage card, the interval can be changed with [+] or [-] on the LCD. (all models 1.109 and model 1.108 version 8.60)		X
[Size Mode]	Shows the selected size channels on the LCD	X	
[Size Mode] and [+] or [-]	Selects the measuring modes: changes mass [ $\mu\text{g}/\text{m}^3$ ] in counts [P/I] or reverse. Selects the size channels to be displayed.		X
[Battery/Location]	Displays the current battery capacity. Displays the location number (1...99).	X	X
[Battery/Location] and [+] or [-]	Displays the current battery capacity. Changes the location number above.		X
[Alarm]	Scans the adjusted alarm value.	X	
[Alarm] and [+] or [-]	Increases or decreases the alarm thresholds.		X
[Date/Time]	Displays the date and time.	X	
[Date/Time]	Short press: displays the date and time. Long press: adjust date/time.		X
[Factor C]	Displays the adjusted gravimetric factor.	X	X
[Factor C] and [+] or [-]	Increases or decreases gravimetric factor.		X
[+]	Periodic display of the analog input values (sensors) will be activated.	X	
[-]	Periodic display of the analog input values (sensors) will be deactivated.	X	
[Mean/Weight] and [Factor C]	Stored data will be deleted and data storage card will be formatted.		X

Key	Function-display During question „Filter Changed? Yes or No“:	Operation mode	Standby mode
[Mean/Weight]	During question „Filter Changed? Yes or No“: Displays the calculated dust weight collected on the filter and the corresponding sample volume.		
[Standby]	During question „Filter Changed? Yes or No“: Displays the serial number <u>and</u> working hours.		
[+] or [-]	During question „Filter Changed?“ Yes or No“: [-] Calculation of accumulated filter weight will continue [+] Calculated filter weight will be reset to zero.		

### 3.4 Sample inlet

The air enters the device via the sample inlet and is forwarded in a straight short way into the optical chamber. The sample inlet is equipped with a pneumatic locking device. Various sampling inlets with an outer diameter of 4 mm can be mounted quickly and gastight without using tools simply by plugging them in into the sample inlet. In order to loose and remove the sampling head, just press and hold the blue plastic lip. According to the application various sampling heads are available.

	<p>Is the device out of operation the sample inlet should be protected by the black plastic cap in order to avoid particles intruding and thus polluting the optical chamber. Is the device in operation an internal rinsing airflow protects the optical chamber from pollution.</p>
--	---

### 3.5 Analog input

The 6-pin analog connection has 3 analog inputs for reception of measurands from different sensors with an output voltage between 0 and 10 Volts. The connection socket besides can provide a voltage of +10 Volts up to 40 mA for powering the sensors.

Possible sensor types can be temperature, air velocity, pressure, CO<sub>2</sub>, or relative humidity sensors. The measured analogue values are sequentially displayed on the LCD and stored on the data storage card. The resolution is 10 Bits (ca. 10 mV). Texts and factors for the LCD-display are adjustable.

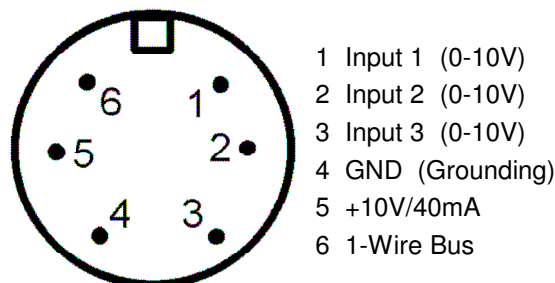

Figure 12: PIN configuration of the analog input



### 3.6 Connection for power supply

The aerosol spectrometer can be power supplied by a mains adapter (18V), which is to be plugged in on the front panel of the device. The socket is for an open DCs power jack, diameter 2.5mm, polarity as written on the instrument. The LED next to the socket indicated the status during battery charging and operation.

Red: 12V Battery is in the instrument and charged with connected 18V mains adapter

Orange: 12V Battery is fully charged

Green: no battery inserted, 18V mains adapter is connected

### 3.7 RS-232 interface

The serial interface is a 9-pin socket located at the front panel of the device, and labelled with "RS-232". Via this interface the dust monitor can be controlled and measurement data can be sent to an external printer or PC. For the interface socket also power supplies the alarm unit it has a specific PIN assignment. Therefore always use the original Grimm RS-232 data cable with catalogue number 1.143E or 1.141, see Figure 6: Recommended accessory for model 1.108 and 1.109.

PIN assignment of the dust monitor's RS-232 interface:

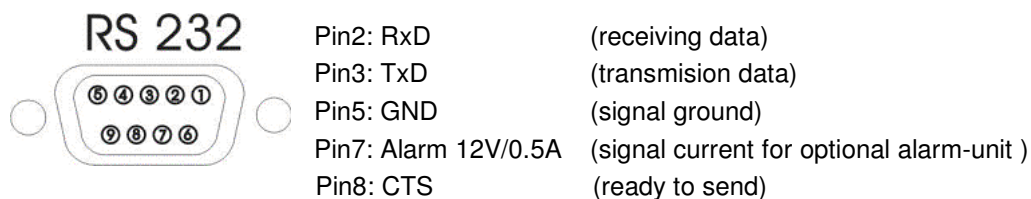

Only use the original Grimm data cable because of the alarm output of the 9-pin RS-232 sub-miniature socket.

### 3.8 Filter chamber

Models 1.108 and 1.109 are delivered with a filter chamber, see Figure 9. The filter chamber has to be equipped with a special 47 mm PTFE-filter. The filter chamber has a bayonet lock and can be opened and closed without any tools. Both O-rings in the filter chamber should regularly be inspected for cracks and deterioration. If those O-rings are defect, false air can be sucked in which adulterates the sample volume flow through the optical laser chamber.

For special applications where no gravimetrical validation of the particle mass is demanded or for measurements of droplet-aerosols, the standard filter chamber can be replaced by a special miniature glass wash bottle with a downstream backup-filter. The miniature wash bottle serves as mist eliminator and particle trap.

### 3.9 PTFE-filter

The sample air is sucked in through a gravimetric filter after leaving the optical chamber. This filter serves as dust collector and can be used for gravimetric controls of the optical gained measurement results (see chapter 4.4, Gravimetric control of the dust mass). Furthermore the particles deposited on the filter can be microscopically or chemically examined. By sputtering with gold the PTFE-filter also can be used for an electron-microscopically analysis.

When operating the device without a PTFE-filter, the dust directly reaches the pump inside the device and might lead to damage or a complete breakdown of the pump.

### 3.10 Warning for laser radiation

On the rear panel of the device is the accordant warning note. Please follow the general instructions for handling lasers and laser radiation described in chapter 1 "Important hints for the customer".

### 3.11 Calibration label

The calibration label on the rear panel shows the month and year until the calibration is valid. After the expiration of validity Grimm Aerosol Technik does not guarantee any accuracy of the measured values within the given allowance. This validation expires in case of a removed or broken calibration label.

### 3.12 Model designation and serial number

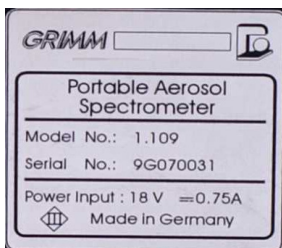

The model designation and serial number is named on the label on the rear panel of the device. The serial number has 8 digits. An example:

9G070031

↳ model: "9" for 1.109, "8" for model 1.108

↳ hardware version: "G" for all 1.109, "F" for all 1.108

↳ year of manufacture, two-digit: "08", "07", etc.

↳ consecutive number of the model in a year: "0001", "0002",...

### 3.13 Sample outlet with end cap

1.2 liter air per minute which have been sucked in through the sample inlet at the front panel leave the sample outlet on the rear panel of the device. The sample outlet is covered by an end cap but not pressure-tight. Is the end cap attached, some of the discharged air leaves the housing through different ports like slots, battery case, or the slot for the storage card. The sample outlet though is necessary for the correct function of certain accessory due to sample air refeeding. Therefore the end cap has to be removed and an according elbow fitting has to be screwed in. Accessories which have to be connected with the sample outlet are for instance the isokinetic sampling set, model 1.152, or the weather housing, model 165FG, with sample dryer and mixer. For this please see chapter 7.1 and 7.10.

### 3.14 Locking feature for battery case and lead storage battery

In order to take the lead storage battery in or out of the device the securing button has to be pressed. The battery engages with an audible clicking. The lead storage battery enables an off line power supply of the dust monitor for 6 to 8 hours. Dust loading of the filter and length of sample inlet system shorten the battery capacity.



#### Safety instructions and lead storage battery maintenance:

In order to guarantee a life expectancy of the battery as long as possible please pay attention to following rules:

- NEVER short-circuit both contacts of the battery.
- The battery must only be recharged via the charging connection of the dust monitor.
- Non-rechargeable batteries (type LCS-2312 AVBNC) must NOT be operated inside the dust monitor with a connected mains adapter at the same time because of the internal charging connection.
- Always use the dust monitor with the provided mains adapter for charging the battery. The dust monitor should be switched off while charging the battery – only then it will completely be charged. The end of charging process can be cognized when the light diode "**Battery Charge**" is off. The charging process lasts for about 4 to 5 hours. Charging a few hours longer does not damage the lead storage battery, nevertheless it should not remain continuously inside the device when the dust monitor is power supplied externally.
- The life expectancy of the battery decreases in case of overcharge or low charge, i.e. if it's not fully charged.
- Use the lead storage battery only to operate the dust monitor.
- Never discharge the battery completely. The dust monitor however does prevent a depth discharge by autonomous disconnection but the life expectancy can be increased if you don't discharge it until the burn out of its capacity.
- If possible, recharge the battery right after usage.
- Do not store the battery discharged.
- Take the battery out of the device if you operate it with a mains adapter. The battery type LCS-2312 AVBNC is not dedicated for operation with a mains adapter at the same time. This shortens the life expectancy. Batteries which are dedicated for this kind of operation (e.g. LCT 1912 AP; 12V; 1,9Ah) have a considerably lower capacity and therefore are rather not that applicable for field measurements.
- Worn out batteries have to recycled according to your country-specific regulations. They contain toxic heavy metals and must not be deposited in the domestic waste!
- The battery's capacity is temperature-dependent! Also charging the battery must only take place within the given temperature range!
- By the way a new battery reaches its full capacity after some charging- discharging cycles.

## 4 System operation

### 4.1 Initiation

The measurement device can be operated in three different ways:

- 1) "**stand-alone-operation**" without PC, with data storage card, controlling via key pad,
- 2) online operation via **Grimm Windows software** with connected PC or
- 3) online via **HyperTerminal control commands** with connected PC.

The following text goes into detail without PC, means "stand-alone-operation". The operation via HyperTerminal control commands is explained in chapter 5 "HyperTerminal via RS-232 interface" and in the following. You can find all details for Grimm Windows software in chapter 11 Software model 1.178.

#### "stand-alone-operation"

In order to take the device properly into operation please follow the steps and annotations beneath.



NEVER operate the instrument without PTFE-filter! Use only the original GRIMM 47 mm PTFE filter!

Please make sure if the gravimetric filter (PTFE-filter), as shown in the picture aside, is correctly inserted. If you want to determine the weight of the dust collected on the filter gravimetrically, please find more information in chapter 4.4 Gravimetric control of the dust mass.

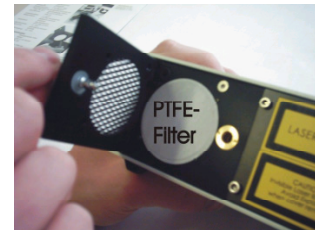

Remove the black protection end cap from the sample inlet.

Insert the data storage card in the designated slot. The data storage card is not mandatory necessary for the operation because the aerosol spectrometer is in possession of an internal 80 kByte memory. However, the storage card enables memorizing long-time measurement rows even with a high temporal resolution.

Plug in the mains adapter or insert the lead storage battery (as shown in the picture on the right side) into the designated case by pressing the locking feature button. The battery has to be completely inside the case and engage with an audible click. The device switches on automatically. Pressing the locking feature button again lets the battery slide out of the case a bit and that way the battery can be taken out. Only remove the battery if the device is switched off.



After switching on the device by the key [ON/OFF] the LCD shows information and actual settings. By short pressing of any key the latency can be abridged. Pressing [Standby] will display the serial number and number of operation hours. Operation time means the service life of the pump and the laser.

<b>MODEL 1.108</b>
<b>VERSION 8.60 E</b>

1.108 version 8.60 (and older) or 1.109 version 12.30.

The "E" indicates the European format for date and time DD.MM.YYYY, whereas the "US" stands for the American format YYYY.MM.DD.

After ca. 10 seconds date and time will be displayed.

<b>Date</b>	<b>28.01.09</b>
<b>Time</b>	<b>9:31:15</b>

With an inserted storage card the LCD shows one after another size of the card (Card), firmware version number (Version), the set storage interval (Interval – can be altered with the keys [+], [-] ), and the free storage space as storage time.

<b>Card</b>	<b>4 MByte</b>
<b>Version</b>	<b>8.60</b>

<b>Interval:</b>	<b>1min</b>
<b>free:</b>	<b>11d13h20min</b>

This complete cycle takes about 20 seconds until the display shows the last question

<b>filter changed ?</b>
<b>press +:yes -:no</b>

Pressing now the [Mean weight] key will allow the user to view the **theoretical filter weight** and the corresponding sample volume since this filter was inserted.

<b>Weight</b>	<b>x,xx</b>	<b>µg</b>
<b>Volume</b>	<b>x,xxx</b>	<b>m<sup>3</sup></b>

The instrument will now prompt the user if the gravimetric-filter should be exchanged. If the answer is yes (by pressing the [+]-key), the calculated filter weight as well as the corresponding sample volume will be reset to zero.

<b>Weight</b>	<b>0,00</b>	<b>µg</b>
<b>Volume</b>	<b>0,000</b>	<b>m<sup>3</sup></b>

By pressing the [-]-key, the instrument continues accumulating the dust mass and sample volume data. In order to prevent an inadvertent erasure of the stored values, the user must press and hold this key for at least 1 second. The operation will be confirmed by an audible "beep". The instrument will then initiate a system self-test and ZERO calibration check.

<b>Self Test</b>
------------------

This process will last for approximately 30 seconds.

If the user wishes to modify any of the operation parameters during this time, the instrument must be switched into the STANDBY mode.

<b>Standby Mode</b>
<b>Press 2nd Key</b>

## 4.2 Measurement

Returning the instrument to the measurement mode by pressing the [standby] key will automatically reactivate the system --test and calibration check. The system self-test and calibration consists of a series of electrical diagnostics and measurements performed with internal "clean" rinsing air to check the optical components. When the system self-test and calibration are complete, the display will indicate

**Self Test OK**

If an error should arise during the self-test, then the following message appears

**New Self Test**

If this news should appear more than once, then the following message appears

**Fatal Error  
Please Check**

There seems to be an application error that must be remedied. Possible causes for this are:

- a fluff, which hangs inside the device at the optical chambers inlet and extends into the laser beam.
- very unclean measurement cell
- an instrument temperature over 50°C
- a laser or another hardware-defect.

First try to remedy the error by a well cleaning of the sample inlet duct. Therefore see chapter 6.3 Cleaning the optical chamber. Otherwise the device has to be sent in to the manufacturer for a service.

Usually the actual dust measurement starts right after the self-test. After every 6 seconds the measurands on the LCD display are refreshed. After one minute the measurands should actually stabilize, because in order to have a pretty stable display always the sliding average of the last minute, i.e. the last 10 measurements, is being displayed.

## 4.3 Measurement mode and data presentation

Within stand-by mode you can switch between operational mode dust mass in [ $\mu\text{g}/\text{m}^3$ ] and particle concentration in [particles/liter] by pressing the keys [Size/Mode] and [+] or [-]. The operational mode is to be selected via the settings in the upper line of the LCD display. Selecting the mode dust mass the display shows on the right side the unit  $\mu\text{g}/\text{m}^3$ ; whereas in the mode particle concentration there is the unit **p/l** on the right side of the display. Select the measurement mode by pressing and holding the key [Size/Mode] and leave the measurement range that appears in the upper line of the LCD upwards by pressing the [+] key, respectively downwards by pressing the [-] key.



Please mention that the data of the chosen measurement mode as they appear on the LCD are of the same type like the data which are recorded by the data storage card, respectively operating via HyperTerminal are sent via the RS-232 interface. That means either mass or particle concentration can be shown or recorded.

Moreover it is possible with the Grimm Windows software to display all four different measurement modes online or to read out and display one and the same stored mass data set from the storage card in three different ways: in terms of occupational health, immission and mass distribution.

Via the Windows software the following operational modes are selectable:

- In terms of occupational health, three dust mass fractions according to EN 481, inhalable, thoracic, and alveolic in  $\mu\text{g}/\text{m}^3$
- Immission, three dust mass fractions according to US EPA, PM10, PM2.5 and PM1 in  $\mu\text{g}/\text{m}^3$

Furthermore the settings like in "stand-alone-operation" are possibly, namely

- Mass distribution, particle mass for all channels including an additional size channel below the smallest size channels as  $\mu\text{g}/\text{m}^3$
- Particle number distribution, particle concentration for all channels as particle/liter.

#### 4.4 Gravimetric control of the dust mass

Due to the fact that the dust monitor does not determine the dust mass directly but indirectly by means of optical light scattering measurement, the results for their respective measurement location moreover have to be corrected with a gravimetric factor – the so-called C-factor. By means of the built-in gravimetric filter the C-factor can easily be determined.



The C-factor depends on the particle density, shape, and refractive index of the particles. It therefore has to be determined for different dust types. This is especially important at workplace measurements for there often appear very different dust types.

Has the C-factor already been determined for a certain workplace, then it can be set before the measurement by pressing the key [C-Factor] and [+] or [-]. The mass per volume will be output accordingly corrected.

Is the C-factor unknown, the measurement takes place with the default value 1 and the gravimetric will be done after the measurement. The according correction of the dust mass of a measurement file can also be done retroactive with the software.



For the gravimetric a microbalance with a high resolution and precision is needed. For a given resolution of  $10 \mu\text{g}$  a minimum of 1 mg dust on the filter is recommended in order to keep a weighing error negligible. The necessary collecting time results out of the existent dust concentration and the sample volume flow.

### Determination of the gravimetric factor (C-factor)

Please execute following steps:

1. Open the filter chamber and take out the old filter. Now clean the filter chamber e.g. with a Q-Tip. Also clean the sample air duct as described in chapter 6.3\_Cleaning the optical chamber.
2. Weigh a new filter (at least three times) and note down the gained average weight.
3. Put the new, weighed filter centred onto the big O-ring of the filter chamber and close the chamber.
4. Turn on the dust monitor and respond to the question "Filter changed?" with YES [+] so that the calculated filter weight will be reset.
5. Execute your dust measurements at a characteristic location. Operate and transport the dust monitor if possible always with the LCD display facing upward.



Please mind, that in case of an eventual interruption of the measurement row the question for a new filter has always to be answered in the negative [-] when switching on the device.

6. The current calculated filter weight can be requested within operational or stand-by mode by pressing the keys [Mean/Weight] and [+]. This is also possible by a control command via HyperTerminal.
7. Having a filter weight heavy enough (at least 1 mg total dust mass) you can exit the measurement by switching into the stand-by mode and subsequently switching off the device.
8. Avoid agitations during transport.
9. Try to take out the filter without losing any collected material. Weigh the loaded filter for a higher accuracy again for at least three times. The difference to the empty filter weight is the effective gained dust mass.
10. Now you can calculate the gravimetric factor according to the equation below:

$$C - \text{factor} = \frac{\text{gravimetric dust weight on filter (loaded filter - empty filter)}}{\text{calculated dust weight (shown by instrument)}}$$

For improving the measurement accuracy one should do the C-factor determination several times. This value should not deviate from the basic value more than ca.  $\pm 30\%$ . However, at metalliferous dusts higher values can occur.



The calculated factor C can now be input into the dust monitor. All dust mass concentration values as well as their averages will be multiplied by this factor and accordingly corrected be output on the LCD display. The measurands on the storage card and the data output via the RS-232 interface will not be corrected. However the gravimetric factor appears in the headline. Thus the evaluation software arranges the necessary mass corrections automatically.



## 5 HyperTerminal via RS-232 interface

Every Grimm spectrometer can be operated with the proper control commands online via HyperTerminal. HyperTerminal is a text-based communication program which is included in the Windows operation system since the version Windows 2.0. Windows Vista does not include HyperTerminal anymore. But it can be updated with costs as download from the webpages of the company Hilgraeve. Alternative distributors are: HyperTerminal Private Edition: <http://hyperterminal.soft-ware.net/download.asp> or Putty: <http://the.earth.li/~sgtatham/putty/latest/x86/puttytel.exe>.

### 5.1 Transmission protocol

The Baud rate for the normal data transmission is **9.6 kBd**. **8 data bits without parity** and **one stop bit** is being used. The software protocol is supported as **Xon/Xoff**. Real time data transfer is possible via the **CTS-cable**. Here the Baud rate can be up to **57.6 kBd**. Also with the ASCII-data-transmission to a printer, by pressing the keys [Mean/Weight] and [Alarm] at the same time (see chapter 3.3, Key functions in the standby mode), the CTS-line will be requested. When no CTS-line is connected then the interface is regarded as free.

### 5.2 Establishing an HyperTerminal connection

Connect the dust monitor via a Grimm RS-232 cable (1.143E) or via a Grimm USB/RS-232 cable (1.141) to a PC and switch on the device.

You will find the HyperTerminal program under:

START->PROGRAMS->ACCESSORIES->COMMUNICATION->HYPER TERMINAL

1) Enter a name for the new connection and confirm with OK.



2.) Choose the right COM and confirm with OK.



3.) Following settings are to be done.

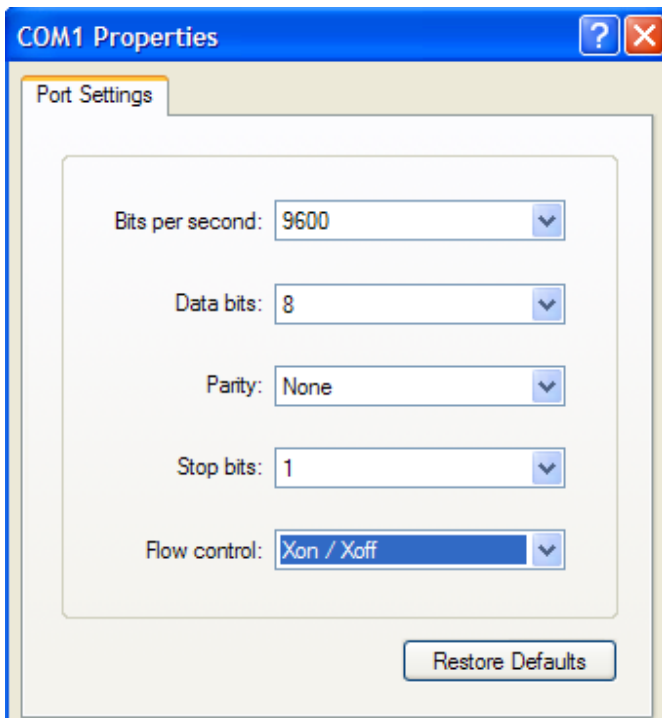

4.) Check the connection by pressing "v". Now the version of the device should appear. If you send a "?" you will get a chart with all possible commands. See therefore the chapter 5.3 RS-232 s. When you established a connection you can change the settings of the measurement device via the according commands, start measurements as well as exit measurements, and record or transmit data. For last mentioned select in the HyperTerminal menu TRANSMISSION and RECORD TEXT.

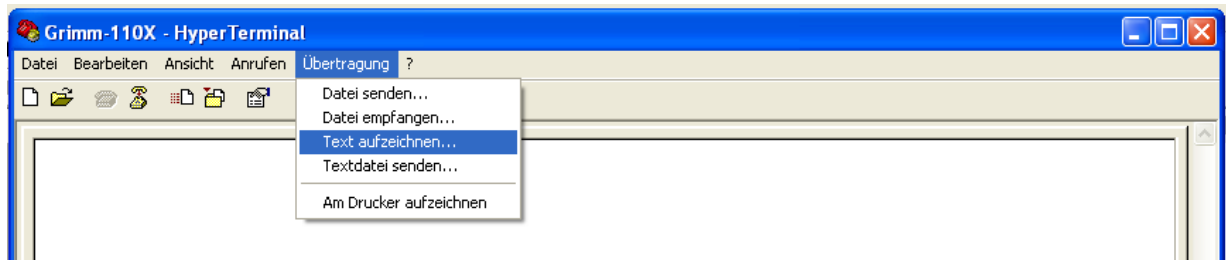

5.) Enter now your favored file name with the ending \*.TXT!

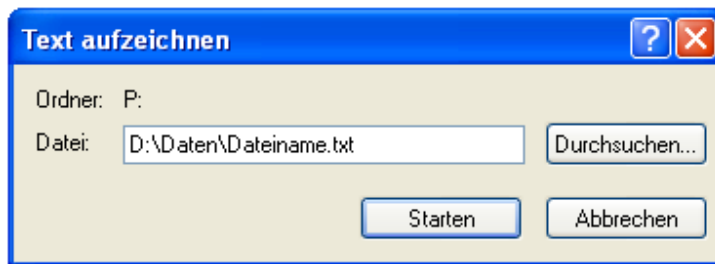

6.) Press now "d" and the following has to appear:

*D*

Memocard : 8.60 from: 8F050061

Location : 1 :

7.) Press now "ENTER" in order to start the data transmission

When the data transmission is completed an "OK" appears beneath the last data set. Hereupon please proceed again to TRANSMISSION-> RECORD TEXT-> EXIT.

### 5.3 RS-232 commands

The text-based commands are sent via the RS-232 interface to the instrument. The instrument will confirm the reception by an echo. For the commands you can use either capital letters or lower case letters. Numeric values, which can only be changed within stand-by mode, have to be concluded with a Cr (Carriage Return, ASCII 13) by pressing the "Enter" key.

For tests you can use every *Terminal program* that supports the **Xon/Xoff-protocol**. The explanations and examples in this manual refer to the program "HyperTerminal" which belongs to the standard accessory of Microsoft Windows. The according settings of the interface parameters have to be determined before starting the device.

**Commands**

- A** Output of the current alarm value. Within stand-by mode it can be altered with keys [+] and [-] in the pregiven interval steps.

*A*

*Alarm : 0 / 1 :*

- B** Output of the battery capacity (with a connected mains adapter the value is always 130%)

*B*

*Battery Power : 11 %*

- ^B** Baud rate set for data transmission:

*0 = 9.600 Baud*

*1 = 19.200 Baud*

*2 = 9.600 Baud same as setting "0"*

*3 = 57.600 Baud*

- C** Switch on count mode / switch off mass display. (at model 1.108 and 1.109 the multiplex-operation will be switched on).

- D** ASCII data transmission of the data storage card (only within stand-by). Example within count mode for model 1.109:

*D*

*Memocard : 12.30 from: 9G040001*

*Location : 2 :*

*P: 5 2 23 14 28 2 0 0 44 13 65 185 0 0 0 1*

*K: 427 800 1611 0 0 35 91 0 0 0 0*

*P: 5 2 23 14 33 2 20 0 42 30 64 185 0 0 0 1*

*C\_: 420648 312631 253253 138895 73489 33731 13396 6428*

*C\_: 3061 2279 1395 647 493 365 274 197*

*c\_: 197 146 110 77 36 18 10 7*

*c\_: 4 2 0 0 0 0 0 0*

*P: 5 2 23 14 56 2 0 0 41 20 64 185 0 0 0 1*

*K: 546 825 1631 0 0 35 91 0 0 0 0*

**Annotation:** The data transmissions for model 1.108 and 1.109 are basically the same. The P and K line is identical. Only the size resolution of the data is different. For model 1.108 the measurement data are listed in two lines (C\_ and c\_) compared to four lines of the 31 size channels for model 1.109 (C\_: C\_; c\_: c\_).

- ^D** Cuts off the measurement data transmission

**E** Output error code (ERROR)

Error Code:	LCD display	Meaning
"128"	NEW SELFTEST	Fault Self-test
"64"	NO MEMOCARD	No storage card or wrong version or card with data of another device
"32"	CHECK NOZZLE	Whirls >5%
"16"	NO OPERATION	Battery capacity = 0%
"8"	PLEASE RECHARGE	Battery capacity < 10%
"4"	PUMP CURRENT TOO HIGH	Motor current $I_{mot} > 100\%$
"3"	FLOW-ERROR	Volume flow control out of control range
"2"	CHECK FILTER	$I_{mot} < 20\%$
"1"	CHECK FILTER	$I_{mot} > 60\%$

**^E** Request for measurand transmission / Switching off the fast mode

**F** Switching on fast mode. The measurands will be output every 6 seconds to the connected PC, independent from the set storage interval. The storage interval for the storage card remains uninfluenced by the fast mode.

**G** Output gravimetric factor. Can be altered within stand-by mode with a step size of 0.05 in the range from 0.1 up to 9.9.

**^G** Bytes per interval. Shows the demand of storage space for the chosen interval.

**H** Output operating hours (Hour)

**I** Interval for normal output and storing onto the storage card. It can be altered within stand-by mode.

0 = 1 Minute

1 = 5 Minutes

2 = 10 Minutes

3 = 15 Minutes

4 = 30 Minutes

5 = 60 Minutes

6 = 6 Seconds

7 = 3 Seconds (only online via Terminal program or Windows software)

8 = 2 Seconds (only online via Terminal program or Windows software)

9 = 1 Seconds (only online via Terminal program or Windows software)

**Annotation:** In order to choose the intervals 7, 8, and 9, the **multiplex mode** has to be **switched off before** with the command "<" or ">"!

For 1.108: lower 8 channels from >0.2 $\mu$ m to >2.0 $\mu$ m, upper 8 channels from >2.5 $\mu$ m up to >20 $\mu$ m.

For 1.109: lower 16 channels from >0.25 $\mu$ m to >2.5 $\mu$ m, upper 16 channels from >2.5 $\mu$ m to >32 $\mu$ m

**J** Output of the channel thresholds in µm (only within count mode)

<i>J</i>								
<i>channel thresholds</i>								
<i>Jc:</i>	0.25	0.28	0.30	0.35	0.40	0.45	0.50	0.58
<i>Jc;</i>	0.65	0.70	0.80	1.00	1.30	1.60	2.00	2.50
<i>jc:</i>	2.5	3.0	3.5	4.0	5.0	6.5	7.5	8.5
<i>jc;</i>	10.0	12.5	15.0	17.5	20.0	25.0	30.0	32.0
<i>Number of particles</i>								
<i>C_:</i>	43167	31404	25011	13215	6935	3095	1290	665
<i>C_;</i>	370	300	180	55	45	40	35	27
<i>c_:</i>	27	11	8	3	2	2	0	0
<i>c_;</i>	0	0	0	0	0	0	0	0

**Annotation:** Different at 1.108 and 1.109. The embodiment of the size channels at the 1.108 and its according particle number is double spaced (*Jc:* and *jc:* resp. *C\_:* and *c\_:*). Compared to that the embodiment at the 1.109 quadruple spaced (*Jc;* *Jc;* *jc;* *jc;* resp. *C\_;* *C\_;* *c\_;* *c\_;*).

**L** Output location number *l* and changing within stand-by mode.

**^L** Country settings for the date format output (only within stand-by mode).  
E for Europe = DD.MM.YYYY or U for US = YYYY.MM.DD.

**M** Output average and sample volume.

<i>M</i>									
<i>Mc:</i>	447430	324824	258999	136537	70110	31757	12825	6485	
<i>Mc;</i>	3357	2574	1640	847	648	493	366	269	
<i>mc:</i>	269	201	154	114	58	32	22	16	
<i>mc;</i>	8	3	1	0	0	0	0	0	
<i>V:</i>	0.0288 m3								

**Annotation:** The output for model 1.108 and 1.109 is due to the different size resolution not the same. The embodiment of the averages for the 1.108 is double spaced (*Mc:* and *mc:*). Compared to that the embodiment at the 1.109 is quadruple spaced (*Mc;* *Mc;* *mc;* *mc;*).

**N** Switch on normal mode (mass display) / switch off count mode.

**O** Output data space size (only within stand-by mode). If you send a + after the capacity output then the data storage will completely be deleted.

**P** Preferences modem submenu

**Q** Quick-data-transfer of the data on the data storage card (only in standby-mode). If the data-transfer takes place via binary-representation the transfer rate can be as quick as 57.6K baud.  
**Annotation:** this command is not listed in the help list of the 1.109 after pressing "?"

**R** Run. Start of the measurement from the stand-by mode

**S** Stop. Switches unit in stand-by mode

**T** Edit Time. Clock can be set in STANDBY mode. If minutes are changed seconds will automatically switch to zero.

**^T** Timer mode for switching the dust monitor on and off automatically. (version x.40 or higher)

**U** Keyboard access

- U=0** Unlocks the keyboard
- U=1** Disables STANDBY mode.
- U=2** Keyboard-access not possible

- V** Displays the version number of the instruments' hardware  
*V*  
*Version : 12.30 E (for model 1.109)*  
*Or*  
*Version 8.60 E (for model 1.108)*
- W** Output filter weight and corresponding sample volume (Weight).  
*W*  
*Weight : 2.4 ug Volume : 0.038 m3*
- ^Y** Power OFF, switching off the dust monitor.
- Z** Output with subsequent resetting of the averages and volume (Zero).
- @** Output serial number  
*@*  
*Ser.No. 9G040001*
- !** Output version and model number of the device.  
*!*  
*Model 1.109 Version 12.30 E*
- \$** Selection or modification of the "User"-texts just like the factors for the analogue voltage output on the LCD-display (only within stand-by mode). Special characters (via ASCII 127) cannot be input. The output shows the character '°'(ASCII 248) as '°' (underline). Given texts can be chosen by pressing the key TAB and have to be confirmed by pressing the return key. They also can be transcribed by any texts. The number output is always five-digit and begins with the ninth position. If characters except of a decimal point are input on this position, an acoustical warning appears. The multiplication factor which is based on 1 Volt can then be input after the text. It also can be changed by the commando `\*`.

Example:

*Temperature sensor: 0 °C = 3.0 Volts and 50 °C = 8.0 Volts*

*User-text: Temp. : °C*

*User-factor: 10.0 [°C/Volt]*

*Offset: 3.00 Volts*

Here is the user-factor the gradient (m) and the offset the Y-axis intercept (c) of the calibration straight line with the general form  $y = mx+c$ .

The model 1.108 and 1.109 offers to read out the sensor data directly from the sensor (sensors with known value "E" or higher – 3 character of the serial number – are being equipped with an EEPROM for the sensor data). Taking over the data out of the EEPROM including the "user-text" will only take place if the "user-factors" inside the device are set on 1.0 and the offset values are 0.0. An afterward calibration by the user is thus still possible (positive offset values are not possible).

- \* Changing user-factors (only within standby mode). The user-factor based on 1 Volt equates to the gradient (m) of the calibration straight line with the general form  $y = mx+c$ , which forms the basis of the conversion of voltage signal to sensor value.

**Long Break** Switching on the dust monitor (if switched off by ^Y).

— (Underline) Output of "User"-texts and analogue input-factors (only within stand-by mode).

Example:

—  
 $\$(1..4):$ Input 1: . V |Input 2: . V |Input 3: . V |Pressure hPa|

$*(1..4):$  1 | 1 | 1 | 179.3722 | 0.000 V | 0.000 V | 0.000 V | 1.880 V |

The first line shows the three "User"-texts. The second line shows first the three multiplication factors for the analogue voltages and then the offset values.

- < Constantly high laser capacity; multiplex mode off.  
 "small particles", 1.108: 8 channels 0.3 $\mu$ m up to 2 $\mu$ m, 1.109: 16 channels 0.25 $\mu$ m up to 2.5 $\mu$ m  
**Annotation:** This command is possible but depending on firmware version it is not included in the 1.109 command help list, after pressing "?". Multiplex mode off is necessary to enable sampling intervals with 3, 2 or 1 second after pressing the command "I" for interval.
- > Constantly low laser capacity; multiplex mode off.  
 "big particles", 1.108: 8 channels 2 $\mu$ m up to 20 $\mu$ m, 1.109: 16 channels 2.5 $\mu$ m up to 32 $\mu$ m  
**Annotation:** This command is possible but depending on firmware version it is not included in the 1.109 command help list after pressing "?". Multiplex mode off is necessary to enable sampling intervals with 3, 2, or 1 second after pressing the command "I" for interval.



**? Help for commands**

**1.108 in normal mode**

```
##### Help for Dust Monitor #####
| A' Alarm | ^L' Land (for Date) [Standby]|
| ^B Baudrate (Memocard) [Standby]| L' Location Code |
| B' Battery | M' Mean Value |
| C' Count Mode [Standby]| N' Normal Dust Mode [Standby]|
| D' Data Memocard [Standby]| O' Clear Memocard [Standby]|
| ^D' Disable Output | P' Preferences Modem [Standby]|
| E' Error | R' Run Measurement |
| ^E' Enable Output | S' Standby Modus |
| F' fast | ^T Timer Set [Standby]|
| G' Gravimetry C-Factor | T' Time Set [Standby]|
| ^G' Byte / Interval | %' Memo free [Standby]|
| H' Runtime hours | U' Unlock Keys [Standby]|
| I' Interval | V' Version |
| J' Output Channels | W' Weight |
| @' Serial-No. | ^Y' Power OFF |
| $' User Strings (Analog Inputs) | Long Break: Power ON |
| *' User Factors (Analog Inputs) | Z' Zero Clear Mean |
| _' Output User Strings + Factors | !' Output Model + Version |
| <' only Channel 1...8 | >' only Channel 9...16 |
#####
```

**1.108 Service Mode 0, additional commands**

```
|
| ~' last Service | X' X-tal |
| ^F' Flow Adjust [Standby]| ':' Preferences Gesytec[Standby]|
#####
```

- ~ last Service. Who did the last service and when was it done. Identification by individual service key and date.
- X** X-tal. Output of the frequency of the quartz from the internal clock on the digital board. Only for trained service staff, if clock-IC or digital board have to be changed.
- ^F** Flow Adjust [standby]. Only for model with internal pump (1.108 or 1.109). With the + and - key the flow rate can be increased and decreased in steps to a maximum of 0.05 liter/min.
- ^V** Change Firmware-Version. No meaning. Only for model 1.105, changes the data displaying. The sign } (ASCII 125) switches to Version 5.x, the sign { (ASCII 123) switches on Version 4.x..  
Example:  
 [ASCII 22] , [ASCII 125] switches on Version 5  
 [ASCII 22] , [ASCII 123] switches on Version 4

Following command is not listed in the 1.108 help list:

**^A** Output calibration factors for analog inputs = identical with \* Changing user-factors

? Help for commands

1.109 in normal mode

```
##### Help for Dust Monitor #####
| A' Alarm | ^L' Land (for Date) [Standby]|
| ^B Baudrate (Memocard) [Standby]| L' Location Code |
| B' Battery | M' Mean Value |
| C' Count Mode [Standby]| N' Normal Dust Mode [Standby]|
| D' Data Memocard [Standby]| O' Clear Memocard [Standby]|
| ^D' Disable Output | P' Preferences Modem [Standby]|
| E' Error | R' Run Measurement |
| ^E' Enable Output | S' Standby Modus |
| F' fast | ^T Timer Set [Standby]|
| G' Gravimetry C-Factor | T' Time Set [Standby]|
| ^G' Byte / Interval | %' Memo free [Standby]|
| H' Runtime hours | U' Unlock Keys [Standby]|
| I' Interval | V' Version |
| J' Output Channels | W' Weight |
| @' Serial-No. | ^Y' Power OFF |
| $' User Strings (Analog Inputs) | Long Break: Power ON |
| *' User Factors (Analog Inputs) | Z' Zero Clear Mean |
| _' Output User Strings + Factors | !' Output Model + Version |
| &' Mixer Humidity Threshold | ;' Autocal [Standby]|
| ]' Analog Sensor Value | |
#####
```

& Mixer Humidity Threshold. Only for Model 1.109 in combination with a outdoor wheather protection housing model 1.165FG.

; Autocal. Instrument will stop during a continuous measurement at a full hour. Measurement will continue automatically after a self-test.

example

;23

Every day at 23:00 (11pm) the measurement will be stopped and the data will be saved. The instrument will carry out a self-test and continues the long term measurement.

] Analog Sensor Value. Only for Model 1.109 in combination with a outdoor wheather protection housing model 1.165FG.

1.109 Service Mode 0, additional commands

```
| | |
| ~' last Service | X' X-tal |
| ^F' Flow Adjust [Standby]| ^V' Version Change |
#####
```

Following commands are not listed in the 1.109 help list:

- ^A** Output calibration factors for analog inputs = identical with \* Changing user-factors
- <** Constantly high laser capacity; multiplex mode off, only Channel 1...16  
"small particles", 16 channels 0.25µm up to 2.5µm
- >** Constantly low laser capacity; multiplex mode off, only channel 17 ...32  
"big particles", 1.109: 16 channels 2.5µm up to 32µm

## 5.4 Service mode settings

By sending the ASCII-rows [124] and [9] or sending the vertical line "|" and press, tabulator the dust monitor will change into the service mode 0. During the data output via the RS-232 interface additional data and explaining texts will be output. In the service mode = some additional commands are available, e.g. date of last service with "~" or adjustment of the flow "^F".

### Example 1:

Pressing key V in the user mode shows the version number of the software:

```
V
Version : 12.30 E
```

Pressing key V in the service mode shows additionally to the version number of the software following details: Creation date of the assembler part, processor type, creation date of the basic part.

(date: dd.mm.yyyy)

```
V
Version : 12.30 E   DM109G 17.12.2007   87C552:011   DM109G 14.12.2007
```

### Example 2:

Normal data presentation in the user mode:

```
P 8 12 10 18 48 1 20 0 130 23 193 1 0 0 0 0
C_: 132940 77350 48435 22270 9325 4610 3210 1795
C_: 1305 1050 765 575 385 280 195 131
c_: 131 82 68 49 33 20 13 10
c_: 7 4 2 1 1 0 0 0
```

Data presentation in the service mode with short explanations of the P-line values:

```
Year Mon Day Hr Min Loc GF Err Qbatt Im UeL Ue4 Ue3 Ue2 Ue1 Iv
P 8 12 10 18 48 1 20 0 130 23 193 1 0 0 0 0
C_: 132940 77350 48435 22270 9325 4610 3210 1795
C_: 1305 1050 765 575 385 280 195 131
c_: 131 82 68 49 33 20 13 10
c_: 7 4 2 1 1 0 0 0
```

## 5.5 RS-232 Data transmission

The data are transferred in three data strings. The actual measurement values in counts or mass, the so called P-line and the K-line with calibration data.

The K-line appears only once after the self-test was completed at the beginning of each measurement. The K-line contents information about the status of the laser diode and the optical cell. More detailed information is given in chapter 6.6.

The P-line is marked with a "P" and contains identifying information corresponding to the Bytes saved on the memory card or send via the serial interface. Generally the P-line appears once every minute or e.g. after each data string in the so-called fast P mode. The P-line is structured as follows:

```
P 10 07 22 15 32 1 20 0 130 23 193 1 0 0 0 6
```

The data in the P-Line have the following labeling:

```
Year Mon Day Hr Min Loc GF Err Qbatt Im UeL Ue4 Ue3 Ue2 Ue1 Iv
```

As follows the meaning of the individual values will be explained with examples (**printed bold**).

```
P 10 07 22 15 32 1 20 0 130 23 193 1 0 0 0 6
```

The first five positions contain the date and time with year, month day, hour and minutes.

```
P 10 07 22 15 32 1 20 0 130 23 193 1 0 0 0 6
```

After this follows the location number, selectable from 1 to 99 and the gravimetric factor. For measurements in the count mode the gravimetric factor will be ignored and set to a default value of 20. In mass mode the gravimetric factor is adjustable. The default value is 1.

```
P 10 07 22 15 32 1 20 0 130 23 193 1 0 0 0 6
```

On position eight the error codes are stored. The error codes are binary coded values from 0 to 128. The meaning of the error codes is listed in the table in chapter 5.3 for the RS-232 command E. A value of 0 means status is fine, no error.

```
P 10 07 22 15 32 1 20 0 130 23 193 1 0 0 0 6
```

The capacity of the battery is indicated at position nine, followed by the current of the internal sample pump. Both values are expressed as a percentage. The value 130 for battery capacity indicates the connection with the 220V power supply. Typically vales for the pump current are between 20 and 40%.

```
P 10 07 22 15 32 1 20 0 130 23 193 1 0 0 0 6
```

The next five values contain special storage space for low Bits (UeL) and for the Bytes of at most four analogue voltages of optional sensors, the pressure sensor on board (Ue4) and the external sensors (Ue3, Ue2, Ue1) e.g. for temperature, humidity and velocity. Values of 0 indicate, that no sensor is connected. The resolution of the voltage signal of the sensors is 10 Bit, so the Bytes indicated with Ue3 to Ue1, show the upper part only. The two low Bits of all four sensors are stored in UeL. Whereas the Bits 0 and 1 belong to Ue1, Bits 2 and 3 to Ue2, and so on. The maximum of the analogue signal is 10 Volt. To get the correct voltage value in the unit volt, the 10 Bit-value has to be multiplied with the factor  $9.776E-3$ . After this, the voltage value is converted into the result value by means of calibration factors of the sensor. This calibration factors can be read by the spectrometer (command `_`) and also edited (command `*`). Furthermore a user-text can be set for each sensor using the `$` command.

Example for the calculation of the temperature using an external sensor for temperature and relative humidity with the following user-text and factors.

```
$(1..4):Temp.: . BC|Humidity . %rH|Input 3: . V |Input 1: . V |
*(1..4): 9.8100006 | 10.62 | 0 | 0 | 2.888 V | 0.063 V | 0.000 V | 0.000 V |
P 10 07 22 15 37 1 20 0 130 23 210 1 0 151 138 6
```

Following values are available: UeL = 210, Ue1 = 138, offset = 2.888 V and user-factor = 9.8100006

The Bit decomposition of UeL gives for the value 210:  $210 = 64*3 + 16*1 + 4*0 + 1*2 = 192 + 16 + 0 + 2$

The fraction for Ue1 from UeL gives the value from 1 of the Bit decomposition = 2

$$\begin{aligned} \text{temperature } [^{\circ}\text{C}] &= (((\text{Ue1} * \text{constant} + \text{value } 1 \text{ of Bit decomposition}) * 9.776\text{E-}3) - \text{offset}) * \text{user-factor} \\ &= (((138 * 4 + 2) * 9.776\text{E-}3) - 2,888) * 9,8100006 \end{aligned}$$

temperature = 24,7°C

Example for the calculation of the relative humidity using an external sensor for temperature and relative humidity with the following user-text and factors.

```
$(1..4):Temp.: . BC|Humidity . %rH|Input 3: . V |Input 1: . V |
*(1..4): 9.8100006 | 10.62 | 0 | 0 | 2.888 V | 0.063 V | 0.000 V | 0.000 V |
P 10 07 22 15 37 1 20 0 130 23 210 1 0 151 138 6
```

Following values are available: UeL = 210, Ue2 = 151, offset = 0.063 V and user-factor = 10.62

The Bit decomposition of UeL gives for the value 210:  $210 = 64*3 + 16*1 + 4*0 + 1*2 = 192 + 16 + 0 + 2$

The fraction for Ue1 from UeL gives the value from 4 of the Bit decomposition = 0

$$\begin{aligned} \text{rel. humidity } [\%] &= (((\text{Ue2} * \text{constant} + \text{value } 4 \text{ of Bit decomposition}) * 9.776\text{E-}3) - \text{offset}) * \text{user-factor} \\ &= (((151 * 4 + 0) * 9.776\text{E-}3) - 0,063) * 10,62 \end{aligned}$$

rel. humidity = 61,9%

The calculation is done in the spectrometer or by the software automatically. The offset-values and user-factors are stored on an EPROM in the sensor and will be read out automatically.

The following pages contain both for model 1.108 and 1.109 examples for data transmission via RS-232 and HyperTerminal commands. In HyperTerminal the values are accumulative only. Differences exist in the displayed. The data in operational mode Counts are generally displayed in the unit particles per liter. If the data output was selected faster than 1 minute interval (e.g. 6 seconds or 3, 2, or 1 second with reduced size range) the unit is particles per 100ml. In the operational mode mass, named "normal" mode in HyperTerminal, the unit is without any exceptions  $\mu\text{g}/\text{m}^3$ . Measurements faster than 6 seconds are not possible in the mass mode.









n2,	225	135	66	0	0	0	0	0
N3,	567	540	514	499	487	480	473	463
n3,	448	376	326	312	98	0	0	0
N4,	693	667	642	626	616	609	604	598
n4,	563	493	424	357	286	286	0	0
N5,	1326	1298	1272	1256	1243	1236	1228	1217
n5,	1180	1115	1039	919	883	785	785	0
N6,	478	450	424	408	399	393	388	380
n6,	347	284	227	134	98	0	0	0
N7,	411	387	362	346	334	327	319	308
n7,	303	253	178	71	0	0	0	0
N8,	445	419	395	381	370	366	358	340
n8,	297	227	165	71	0	0	0	0
N9,	1502	1474	1447	1432	1421	1414	1404	1390
n9,	1382	1316	1259	1206	1170	1072	785	0





C21;	195	145	115	90	70	60	35	30
C22:	16615	10505	6370	3380	1505	890	640	380
C22;	265	220	185	140	80	60	35	30
C23:	15910	10150	6410	3485	1610	825	580	340
C23;	220	185	165	120	90	85	55	25
C24:	15975	10265	6205	3405	1725	925	630	360
C24;	230	185	140	110	95	75	50	35
C25:	16220	10095	6305	3350	1600	790	600	340
C25;	205	190	135	90	65	55	40	30
C30:	16990	10675	6570	3620	1650	925	640	400
C30;	290	230	170	125	80	65	50	30
C31:	16690	10440	6640	3710	1760	1050	710	425
C31;	275	220	150	115	90	70	50	20
C32:	15855	9990	6195	3435	1670	840	570	290
C32;	185	155	115	70	50	40	20	15
C33:	16840	10570	6690	3665	1770	840	605	335
C33;	255	200	140	110	75	60	45	30

**2 sec interval: 16 channels >0,25µm to >2,5µm in P/100ml**

	Year	Mon	Day	Hr	Min	Loc	GF	Err	Qbatt	Im	UeL	Ue4	Ue3	Ue2	Ue1	Iv
P	8	12	10	11	31	1	0	64	130	14	5	4	0	0	0	8
C00:	16305		10442		6597		3662		1800		982		632		395	
C00;	272		220		192		147		117		105		75		52	
C02:	15862		10097		6237		3497		1630		870		595		350	
C02;	260		217		165		142		102		72		45		27	
C04:	16182		10197		6372		3527		1737		852		615		330	
C04;	225		190		152		110		77		67		35		22	
C10:	16482		10480		6570		3597		1777		947		672		417	
C10;	265		230		175		140		102		75		65		45	
C12:	16210		10112		6325		3555		1755		967		685		392	
C12;	262		222		160		120		82		62		42		32	
C14:	16170		10182		6275		3457		1585		870		612		360	
C14;	240		190		142		120		67		45		30		22	
C20:	16365		10267		6442		3592		1615		870		615		355	
C20;	252		200		165		122		75		60		40		27	
C22:	16385		10425		6530		3587		1705		892		657		397	
C22;	282		220		185		137		92		70		52		27	
C24:	15987		10085		6375		3425		1665		880		587		335	
C24;	220		170		135		100		65		47		32		27	
C30:	15520		9662		6180		3330		1545		915		620		372	
C30;	290		240		205		162		100		75		42		27	
C32:	15790		10032		6342		3597		1687		910		645		375	
C32;	245		220		180		145		115		85		55		40	





## 6 Maintenance and cleaning



It is recommended to execute following points annually!

### 6.1 Filter chamber

The filter chamber is to be cleaned with every filter change with a Q-Tip or a lint-free cloth. Tenacious stains can be removed with special cleaning cloth like as they are used for computers.

### 6.2 Filter change

Switch off the device. Unlock the filter chamber by turning the bayonet lock. Older models have a screw instead of the bayonet lock. The screw is provided with a protection so it cannot fall out. Carefully open the lid. Now take out the old filter using appropriate tweezers. Avoid that collected dust on the filter gets into the instrument and contaminates the optical cell.

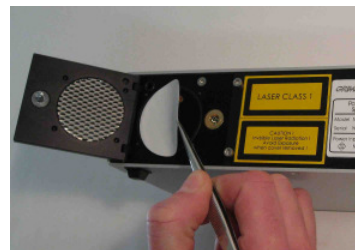

Clean the sample air duct (see chapter 6.3) and the filter chamber like described above.



Using the tweezers put now a new filter centrally onto the big O-ring of the filter chamber. The filter should not contact the small O-ring. If you want to do a gravimetric analysis you should regard the instructions given in chapter 4.4 Gravimetric control of the dust mass. Close and lock the lid paying attention the filter does not get out of place.



The maximum battery operation time as well as the durability of the pump decreases with an increasing filter impact. Thus change the filter early enough; at the latest with the accordant warning message. Loading the filter with more than 20 mg should possibly be avoided.

### 6.3 Cleaning the optical chamber

Turn off the device.

Open the filter chamber and remove the gravimetric filter.

First inspect the air passage optically for free sight through the instrument. The aerosol duct of the optical chamber is straight and thus you have to be able to see through it. Then flush the instrument with clean and oil-free compressed air (max. 3 bar). This must be done in direction of the airflow, only, from the air inlet located on the front side of the device to the filter chamber. Eventual blockage of the aerosol nozzle in the optical chamber is to be removed with a wooden or plastic rod (do not use any stronger materials in order to avoid damage of the nozzle!).



Do not drag any implements (e.g. cloths, etc..) through the inlet nozzle or demount it!  
Please contact our service department for any help and assistance!

### 6.4 Housing

The dust monitor is encased by a metal housing, which ensures against mechanical impacts and electromagnetic fields. The keypad and the LCD window are to be protected against abrasive mechanical impacts. For cleaning the housing use a dry cloth and for removing tenacious stains use special cleaning cloths like as they are used for computers.

### 6.5 Internal rinsing air filter

For the protection of the laser optics and for the self-test of the device particle-free air is generated by a fine filter with a life expectancy of several years even at continuous operation. Should the message

**„CHECK NOZZLE  
AND AIR INLET“**

show up several times although the sample inlet duct is free and also having no over-pressure out of range this is a sign of an error within the rinsing air supply. However changing the filter has to be done by a trained service staff and can mostly solve this problem. In this case please contact your local dealer, the manufacturer or the service department in Pouch, Germany.

### 6.6 K-line, test of functionality of the optical cell, laser diode and photo diode

During the self test procedure all components of the optical cell, namely photo diode and laser diode, and their functionality were tested and controlled. The results are displayed in the so called K-line, if the unit is operated via HyperTerminal. The values in the K-line will be explained with full details below.



DC/v DC\_d DC\_h C0\_h C0\_d La\_l La\_h  
 K 740 1318 1469 0 0 60 106

The value DC/v indicates the DC voltage of the photo diode without the bias voltage (offset-value) of the pre-amplifier. This value acts as referee and is without further meaning for the customer.

DC/v **DC\_d DC\_h** C0\_h C0\_d La\_l La\_h  
 K 740 **1318 1469** 0 0 60 106

The photo diode induces an open-circuit voltage during the laser diode is switched off. This open-circuit voltage is called DC\_d, whereas d means "dark". A value of 1318 in the K-line corresponds to a voltage of 131,8 mV.

If the laser is switched on, the voltage at the photo diode will increase, in the example above to 146,9 mV. This means the h in DC\_h means "high". The increase of the DC voltage results from the rest light of the laser, e.g. due to reflexion in the optical cell. The better part of the laser light is absorbed by the light trap.

Both the DC\_d and the DC\_h value are variable, and depend e.g. on temperature. The difference between the DC\_h and DC\_d always should show a nearly constant value. In the example above app. 15 mV (146,9mV – 131,8mV). Herby this difference is a good indicator for the condition of the optical cell.

If the difference between DC\_d and DC\_h remains not constant, the optic has to be cleaned or repaired. The set-value for the DC\_d and DC\_h difference is listed for each device in the last service protocol or for new devices in the quality assurance protocol of the calibration certificate.

If the condition of the optical cell changes e.g. by dirt this difference will rapidly increase. A fluff, trapped in the aerosol inlet nozzle and extending into the laser beam, easily can increase the DC\_h value up to 65000. A difference value close to zero e.g. like 2,3 mV is typically for a broken laser diode. A damaged laser diode emits very weakly in the infra red only, very similar to a red LED, whereas the photo diode is very sensitive on infra red radiation.

DC/v DC\_d DC\_h **C0\_h C0\_d** La\_l La\_h  
 K 740 1318 1469 **0 0** 60 106

Both C0\_h and C0\_d allways has to be 0.

C0\_h means Counts without particle or zero counting with laser switched on, that explains the \_h for "high". During the self test procedure the optical cell is flushed with particle free rinsing air, causing a slight over pressure in the optical cell. Thus no particles can enter the optical cell and the signal must be 0. A value greater than zero indicates particles in the optical cell, e.g. due to a leak in the sampling air circuit.

Also with particle free reference air but the laser switched off the C0\_d is determined, that's why the d means "dark". A C0\_d value different to zero indicates a failure of the signal amplifier. Since without laser light no scattering can arise the signal must originate from the electronic noise. This indicates a failure of the signal amplifier

DC/v DC\_d DC\_h C0\_h C0\_d **La\_l La\_h**  
 K 740 1318 1469 0 0 **60 106**

The laser diode in the Grimm aerosol spectrometer (model 1.108 and 1.109) is operated in alternating with two different laser power, the so called Multiplex-Mode. La\_l "low" means low laser current in mA and La\_h "high" means high laser current. If the La\_h current increase between 180 to 200 mA, the laser diode is broken.

It also can happen, that the laser diode is fine but the soldering connection of the poti on the small laser driver board has broken. A broken poti for the high laser current shows  $La_h$  values at about the same range of the  $La_l$  value. A broken poti for the low laser current is much more sophisticated, because the 0.5mW power in the low laser operation mode is quite small. Due to some reference resistors the  $La_l$  and  $La_h$  values will not drop to 0.

For new instruments a quality assurance protocol with all K-line data from the manufacturers calibration is delivered, for comparison.

## 7 Accessory

Product No.	Description
1.111	Radial symmetric sampling head
1.145A	Black leather spectrometer protection bag with shoulder strip
1.147	Acoustic and visual alarm unit
1.148	Mini filter for 0-test
1.149B	Spare part set for second year
1.151A	Clean room sampling heads for air speeds 0.5; 1; 2 and 4 m/s
1.152	Isokinetic sampling set for air speeds 2-25 m/s (4 nozzles)
1.153FH	Sensor for temperature and relative humidity
1.154	Sensor for temperature, relative humidity, and velocity
1.156	Diff. Pressure sensor for basic instrument (built-in)
1.162	Plug for analog socket
1.301	Indoor PAH-sensor, measures particle bound PAH concentration as sum signal (needs the 1301 HLX carrier as well)
1.301 HLX	Carrying adapter for 1301 for PAH to combine with aerosol spectrometer 1.108 or 1.109
1.320	NanoCheck, portable nano attachment, measures particle concentration and mean diameter from 25 - 300 nm (needs the 1365 HLX carrier as well)
1.365 HLX	Carrying adapter for 1320 NanoCheck to combine with aerosol spectrometer 1.108 or 1.109
165FG	Weather protection housing

### 7.1 Sample inlets

In order to have a possibly small measuring error when sampling one should take care that preferably no difference between the velocity of the aerosol to be measured and the velocity of the aerosol at the inlet of the measurement unit is existent. This kind of particle measurement sampling is called **isokinetic** sampling.

Because the dust and particle measurement devices are equipped with a volume flow control (1.2 l/min) the intake speed can be determined exactly due to the geometry of the sampler.

Depending on the application an appropriate sampler should be used. For that purpose following models are offered by the manufacturer:

#### Radial symmetric sampling head (model 1.111)

**APPLICATION AREA:** For indoor and outdoor measurements (IAQ) up to an air motion of ca. 2,5 m/s from different directions. The radial symmetric sampling head is conform to the regulation EN 481 for measurements at workplaces and guarantees an intake speed of 1.25 m/s at the opening slot.



### Clean room sampling heads (model 1.151A)

**APPLICATION AREA:** For measurements in a flow range up to 4 m/s where the air leaves with a relatively constant speed and into a defined direction, e.g. after filter systems or inside laminar flow boxes.

A representative sampling at particle measurement requires an isokinetic sampling. This condition is only given at even velocities between main flow and sample flow. This sampling heads are appropriate for air speeds of 0.5, 1, 2, and 4 m/s due to four different nozzles. The appropriate nozzle is to be selected after determination of the air velocity at the measurement location. The sample inlet has to face always head-on towards the air direction. The sampler can either be plugged directly into the sample inlet of the device or into the accordant positioned stand. In the last case the sampler has to be connected via a hose as short as possible with the measurement device in order to keep particle loss through sedimentation as small as possible.

Depending on the speed of the emerging air following inlet nozzles are available:

-red nozzle:	up to 0.5 m/s
-golden nozzle:	0.5 up to 1.0 m/s
-green nozzle:	1.0 up to 2.0 m/s
-blue nozzle:	2.0 up to 4.0 m/s



### Isokinetic sampling head for 2 up to 25 m/s (model 1.152)

**APPLICATION AREA:** Sampling and particle measurements out of air ducts or stacks, before or behind filters, in ventilation systems and deaerators.

This sampler was especially developed for dust measurements inside air ducts. Due to the back loop of the sample air an application also at over- or low-pressure up/down to **100 mbar** is possible. The channel therefore has to be equipped with a fitting aperture (**diameter 35 mm**). Because of the scale on the sampling pipe measurements can be done simple and fast according to VDI 2066. If measurements do not happen under normal pressure then eventually a conversion to standard cubic meter of the sample volume has to be done. Then the measuring results have to be accordingly corrected.

The probe exists out of following components (sketch indices prefixed):

- (2) Four nozzles for the speed ranges 2-4, 4-8, 8-16 and 16-25 m/s. The nozzles opening diameter is reverse proportional to the speed.
- (3) 90° probe bend.
- (4) Opening for outlet of the sample air back loop.
- (7) Channel carrier.
- (8) Probe extension 250 mm, optional.
- (9) Connection piece to the measurement device and air recirculation  
0.5 m hose 3\*6 mm optional extension for connection with the measurement unit.
- (10) Swing fixture for connection of the sample air refeeding.  
Wrench 8\*10 for changing the nozzle and fastening the swing fixture on the rear side of the device. As well as (1) air duct, (5) sample air to the measurement device, (6) exhaust air recirculation.



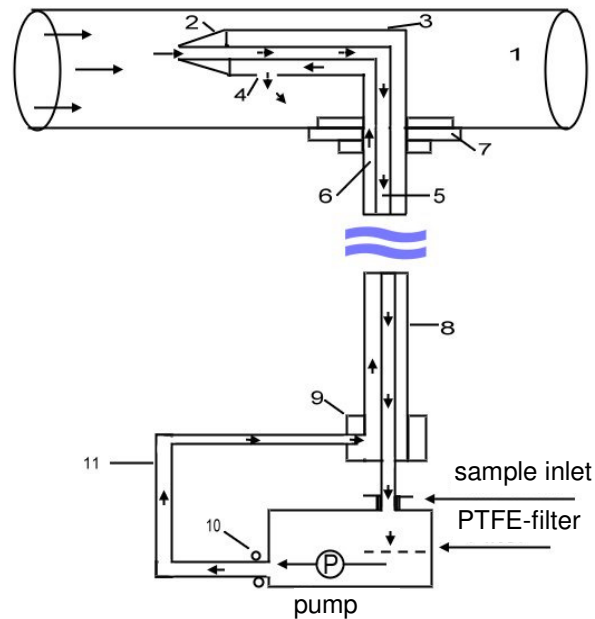

Figure 13: Function principle of the isokinetic sampling probe

### Installation of the sampling probe 1.152

Hereinafter pictures show from left to right the essential steps for connecting the sampling probe with the dust monitor.

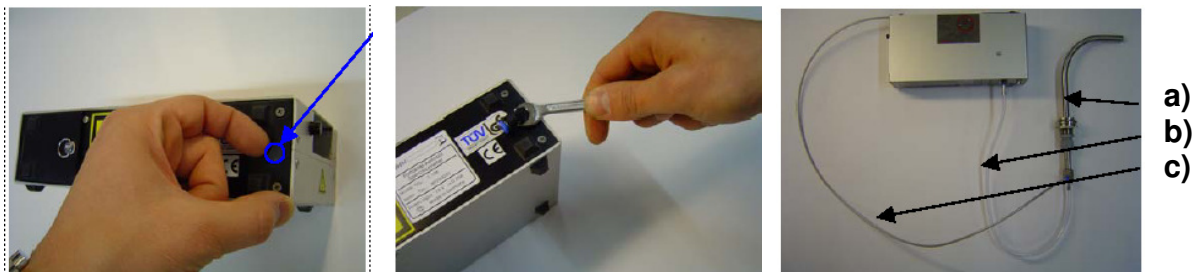

Figure 14: Installation of the sampling probe, a) sampling probe, b) lucent tube, c) sample air refeeding

In order to be able to screw in the angulated connection piece the end cap of the sample outlet on the rear side of the device has to be removed as shown in the left picture. By means of the provided 8 mm wrench the plug connection can be screwed in and hand-tight retightened. Afterwards connect the spare components pneumatically. For the sampling head the 90° bend probe a) has to be used because only at this part the recirculated sample air can leave the probe through the small opening. The straight extension does not have this opening. The lucent silicone tube b) serves as flexible extension to the sample inlet of the dust monitor. The grey PVC hose c) leads the sample air back (sample air refeeding).



Note: In order to keep particle losses through sedimentation as little as possible the distance between the sampling head and the sample inlet should be as short and straight as possible as well as straight respectively vertical. It would be best to connect the sampling head directly with the dust monitor without using the flexible extension b) or cut it to a minimum length!

### High pressure diffuser for compressed air (model 7.910)

The GRIMM "High-pressure diffuser for compressed air 7.910" was designed to reduce the pressure from inside a compressed air line to ambient pressure. This enables a sampling with an Aerosol Spectrometer operating with a volume flow rate of 1.2 liter/minute. The 7.910 was designed to user specifications for maximum pressure of 10 bar and for isokinetic sampling both on air-inlet and air-outlet. To obtain isokinetic sampling it is necessary to select the correct inlet-nozzle and the outlet tube. To select these parameters correctly, a set of two calibration diagrams is enclosed to each diffuser.

For the model 7.910 a separate manual is available.



### 7.2 Black leather spectrometer protection bag with shoulder strap (model 1.145A)

The protection bag is designed for portable use of the spectrometer. The instrument is well protected against dirt and shocks. Connections for sample inlet, optional sensors or serial port are accessible, also the LCD-display can be read easily when the bag is closed.



### 7.3 Acoustic and visual alarm unit (model 1.147)

Connect the alarm unit directly to the RS-232 socket of the dust monitor. If the set alarm value is exceeded, the alarm unit signalizes this optically and acoustically. Due to 5 DIL switches and one potentiometer in the alarm unit 24 different signal tones can be chosen as well as changing the volume.

#### Technical data:

Weight	0.42 kg
Dimensions:	Ø = 93 mm, H = 115mm
Plug:	9-pin D- sub miniature
Power supply:	12V, 0.15A
Flash energy:	1.0 J
Flash frequency:	1 Hz
Signal tone:	24 different
Volume:	up to 110 dB(A)



### 7.4 Mini filter for zero test (model 1.148)

By means of this filter, the dust monitor can be checked up on hissing of the signal electronics and up on leakages in the pneumatic system. When the filter is connected to the sample inlet of the dust monitor the sliding average values at the LCD display have to go back to zero after on minute. Data displayed online in HyperTerminal or via Windows Software have to go back to zero immediately. The increase of the pump motor current there to more than 60% and with this the aligned possible warning message is here normal.



## 7.5 Sensor for temperature and relative humidity (model 1.153FH)

This sensor is due to the fact of its low current consumption suitable as an accessory for a portable battery-powered instrument. The sensor values can be shown online on the LCD-display, via HyperTerminal or in the sensor window in the Grimm Windows software. The knowledge of relative humidity is fundamental for interpretation and analysis of aerosol measurement data.

### Technical data:

Dimensions:	Ø = 15 mm, length = 130 mm, cable: ca. 2m
Plug:	6- pin
Power supply:	10V ±5%, < 5 mA
Temperature range:	0.3 up to +80 °C
Resolution:	0.1 K
Accuracy:	typically 0.3 K
Humidity range:	0 up to 100 % rH
Resolution:	0.1 %
Accuracy:	typically 1 %



## 7.6 Sensor for temperature, relative humidity and air velocity (model 1.154)

This sensor is like the model 1.153FH but in addition equipped with an integrated anemometer for air speed velocity. The compact design of the sensor is optimised for the use in combination with the isokinetic sample probe and the direct determination of air velocity in ducts. Another application is monitoring of wind speed in one preferential direction during particle measurement, e.g. for source studies or ventilation control.

### Technical data:

Dimensions:	Ø = 15 mm, length = 130 mm, cable: ca. 2m
Plug:	6- pin
Power supply:	10V ±5%, < 5 mA
Temperature range:	0.3 up to +80 °C
Resolution:	0.1 K
Accuracy:	typically 0.3 K
Humidity range:	0 up to 100 % rH
Resolution:	0.1 %
Accuracy:	typically 1 %
Air velocity:	0.3 up to 20 m/s
Resolution:	0.1 m/s
Accuracy:	typically 1%



## 7.7 Plug for analog socket

Via the analog socket the spectrometer is able to log up to three signals of any sensor, with an analog output 0 - 10V. To use any customized sensor a suitable 6-pole analogue connector has to be used. The Pin setting are as followed: Pin1: Input 1, Pin2: Input 2, Pin3: Input 3, Pin4: GND, Pin5 +10V/40mA, Pin6: 1-Wire Bus.

## 7.8 PAH-sensor (model 1.301) and adapter kit (model 1.301-HLX)

This sensor measures the total concentration of particle bound polycyclic aromatic hydrocarbons (PAK resp. PAH). The sensor does not possess an own sample air pump and thus is supplied by the dust monitor. The measured data is transmitted via the serial RS-232 interface to the dust monitor. The PAH-sensor and the dust monitor are being mounted together into an adapter kit. This enables a mobile, battery-powered application. With an installation inside a weather protection housing the data transmission occurs via the analog socket of the dust monitor. The power supply takes place by means of a cable adapter via the mains adapter of the dust monitor.

### Technical data:

Sensor dimensions:	240 x 75 x 75 mm (9.45 x 2.95 x 2.95 inches)
Weight sensor only:	1.75 kg (3.9 lbs)
Power supply:	10 - 28 VDC; < 1,2 A (max.)
Battery	12VDC lead battery
Plug:	9-pin SUB-D & low-voltage socket
Interface:	RS-232, 1-wire, analog-out; I2C
Measuring range:	up to 5000 fA max. (settable)
Sensitify:	< 1 ng/m <sup>3</sup> (aerosol-dependent)
Resolution:	>= 12 Bit
Data rate:	<= 6 s up to 2h (settable)
Status display:	LED's

Adapter dimensions:	320 x 115 x 290 mm (12.6 x 5,5 x 11.4 inches)
Weight adapter only:	3.4 kg (7.5 lbs)

Weight complete system with sensor, adapter and spectrometer:	6.85 kg (15.1 lbs)
---	--------------------



Complete system closed



Complete System open

The adapter set possesses a battery for the integrated PAH-sensor and thus enables field measurements without an external mains adapter. The PAH-sensor is connected to the dust monitor via the analog socket #3. The other analog inputs #1 and #2 are still accessible via an analog socket at the end plate of the 1.301-HLX.

Both instruments 1.108/1.109 and 1.301 can be power supplied with the standard mains adapter of the measurement device. On the right end plate of the 1.301-HLX is a supply socket (same type as at the dust monitor).



For both models 1.301 and 1.301-HLX separate manuals are available.



## 7.9 NanoCheck model 1.320 and adapter kit 1.365-HLX

The NanoCheck measures the total number concentration and the mean particle diameter of the nano scaled aerosols in the range 25nm to 300nm, which is directly next to the range of the Grimm Aerosol spectrometer.

The nano counter attachment model 1.320 can be added to any Grimm Aerosol spectrometer, getting the sample directly from the spectrometer which also displays and logs the data. Both the nano counter attachment and the spectrometer are mounted in an adapter kit, model 1.365 HLX. With this setup it is possible to monitor the full aerosol size range including the ultra fine particles with one battery powered portable system. In combination with a Grimm Aerosol spectrometer the complete system is able to measure in real time the particle size range from 25nm up to 30 µm in different size channels.

In addition to the classically measured inhalable, thoracic and alveolic mass fractions according to EN 481 standard it is a huge benefit for IAQ monitoring, occupational safety and health and other applications in aerosol science, to measure the nanoparticle exposure down to 25nm. This will help to understand the influence of nano aerosols on the inhalable aerosol concentration.

### Technical data:

Sensor dimensions:	240 x 75 x 75 mm (9.45 x 2.95 x 2.95 inches)
Weight sensor:	1.8 kg (4.0 lbs)
Power supply:	10 - 28 VDC; < 1,2 A (max.)
Battery	12VDC Lithium Ion battery
Plug:	9-pin SUB-D & low-voltage socket
Interface:	RS-232, 1-wire, analog-out; I2C
Measuring range:	
Particle size	25nm to 300nm
Number concentration	5000/ccm to 500 000/ccm
Sensitivity:	Depending on size distribution and number concentration
Resolution:	>= 12 Bit
Data rate:	10 s
Status display:	LED's
Adapter dimensions:	380 x 115 x 290 mm (15.0 x 4.5 x 11.4 inches)
Weight adapter:	4.7 kg (10.4 lbs)
Weight complete system with sensor, adapter and spectrometer:	8.2 kg (18.1 lbs)



Complete system closed, with attached dryer



For both models 1.320 and 1.365-HLX separate manuals are available.

### 7.10 Weather protection housing (model 165)

High air humidity usually leads to incorrect measurements at optical working dust monitors for the water molecules will be recognized as particles and thus falsify the measurands. But in order to be able to do measurements in spite of those bad conditions occurring in the nature, a specific weather protection housing was developed. This contains an annular gap mixer by which particle-free dry air can be refed to the sample airflow. This method decreases the relative air humidity so that even in case of high humidity values reproducible dust measurements can be done. The controlling of the mixer electronics that controls the proportion of particle-free dry air and sample air happens via the dust monitor. At the device a certain humidity threshold value can be set starting from which the mixer is to be activated. If the mixer is switched on, amount of the air sucked in by the device remains constantly 1.2 l/min, however the sample air will be diluted 1:1. The software takes this into consideration when calculating the dust fractions, the filter weight, and its according volume flow. For generating the dry and particle-free mixed air the exhaust air of the aerosol spectrometer is being used which therefore passes a silica-gel dryer and a filter. The mixer electronics ensures that the amount of exhaust air and mixed air is always the same. If the system is definitely airtight the proportion sample air to mixed air is 1:1.

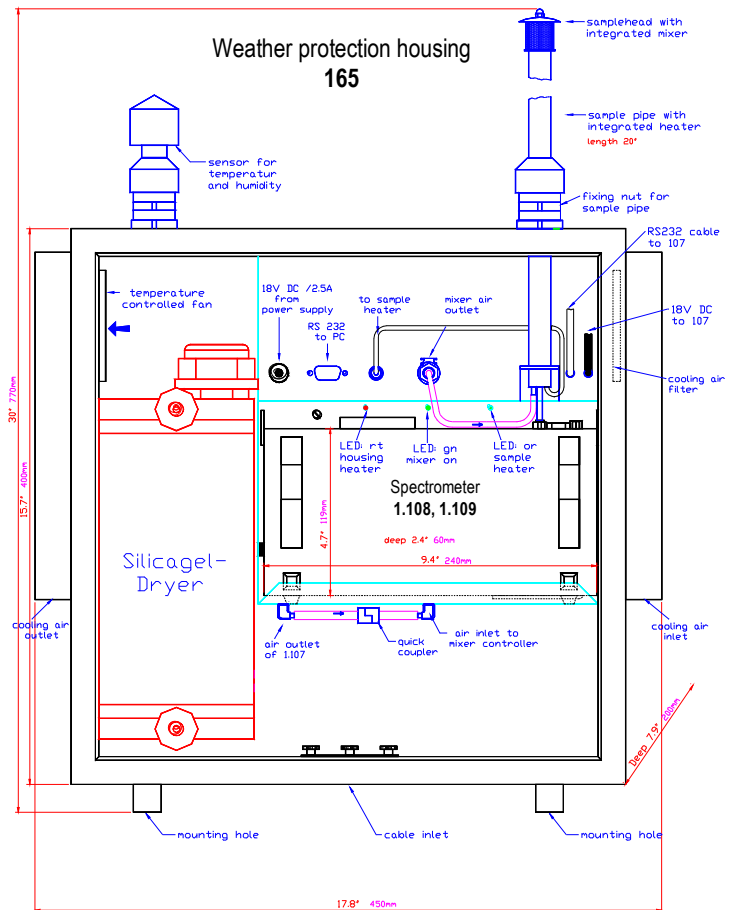



Figure 15: Weather protection housing (165) with dryer, mixer electronics and sampling head with integrated annular gap mixer.



For model 165 a separate manual is available.

## 8 Warranty

GRIMM Aerosol Technik guarantees every customer that the in this document described device is developed, constructed, and manufactured according to the best technical requirements for the described application. Furthermore is guaranteed that this device has no material defect and was delivered free of assembly errors after passing a severe quality check. However no further warranty is given for an application-specific function not for damages emerged from material or assembly faults. Every device is seized by the production and journalized most accurately especially the calibration and validation data.

Should the device fail during the 1-year warranty or not being up the standard GRIMM Aerosol Technik has the right to replace the faulty parts or the device apart from operating errors.

GRIMM Aerosol Technik will fix the device at the factory exempt from charges; only the transport fees just as the accordant additional charges are for the customers account. On-site repair will only be done for refunding the travel and service costs. The company GRIMM is not in charge for further claims, which can be educed from the warranty.

GRIMM takes over the warranty of the sold goods only if those are being used under normal conditions and according to the instructions in this manual. The warranty expires after 12 months, beginning with the day of delivery. Return consignment charges for repair under warranty are to the customers account.

This warranty has following exceptions:

- a) For spare parts, which will be replaced or repaired under warranty in order to make operation possible again we take over warranty for 90 days, normal use preconditioned.
- b) The supplier is not liable for third's party products or batteries of consumables; only the original warranty is held up.
- c) Without written confirmation GRIMM does not give warranty on third's party products which have been modified or built in or out by untrained service staff.
- d) Everything mentioned above substitutes other warranty agreements respectively restrictions. No further liability claims will be given especially beyond normal usage.
- e) Usage and operation is within the customers RESPONSIBILITY. He has to obey the legal restraints and claims and has to operate the device according to the lawful and operational purpose. Deviations lead to warranty exclusion.
- f) Legal measures against the company GRIMM no matter from which side after a time-period of 12 months is baseless without exception.
- g) The buyer just as the seller both agree that this WARRANTY RESTRICTION, which form the claims, and restrictions shall not being questioned. Both parties are registered traders under German Commercial Code.
- h) In case of a legal action the place of jurisdiction is Traunstein, Germany.

## 9 Transport

The product described in here is delivered in a cardboard box. Please assure yourself that the shipment is complete and without visible damages. If you spot damages due to the transport, you have to reclaim them immediately. In this case you must not take the device into operation for safety reasons. In order to protect the device from future transport damages we recommend to keep the original packaging.



If the device is equipped with a transit support, they have to be reinstalled previous to the transport.



Particularly after transport under low temperatures a sufficient acclimatization phase has to be maintained, otherwise damages can result.

## 10 Repair

Having knowledge that defect or inactive devices cause disprofit, it is Grimm's politics to care as fast as possible about those customer issues. If an idleness/ breakdown is ascertained, we kindly ask you to immediately contact the next GRIMM selling agency or you local dealer.

Please contact the service department of the company GRIMM via Email before you send one of our devices back for service:

[Service@grimm-aerosol.com](mailto:Service@grimm-aerosol.com)

Please specify with following details:

- Device's model number
- Serial number and year of manufacture (see name plate on the back of the device)
- Date of purchase order and your order number (except in a case of warranty)
- Your invoice address
- Your shipping address



Please make sure that the device or devices are free of any contamination dangerous to health before shipping the device or devices!

## Index

<b>A</b>	<b>K</b>
alarm threshold ..... 30	key functions ..... 25
alarm unit ..... 17, 33, 67, 70	keypad ..... 21, 25
analog input ..... 19, 21, 32	K-line ..... 52, 64
<b>B</b>	<b>L</b>
battery ..... 25, 27, 30, 35	laser diode ..... 18
battery capacity ..... 44	laser radiation (safety) ..... 9, 34
battery charging ..... 35	LCD-display ..... 19, 21, 22
battery error code ..... 45	leakage ..... 70
battery maintenance ..... 35	location ..... 27, 30, 31, 46
battery recycling ..... 35	
baud rate ..... 44	<b>M</b>
blockade ..... 64	measuring principle ..... 11
<b>C</b>	memory function ..... 19
calibration ..... 13	multiplex (laser) ..... 11, 18, 44, 45, 48, 50
C-factor ..... 39	
coincidence ..... 28	<b>N</b>
communication ..... 19	normal mode ..... 46
compressed air ..... 17, 64, 70	
control elements ..... 21	<b>O</b>
CTS-cable ..... 41	offset values ..... 48
<b>D</b>	operation hours ..... 37
data interface ..... 19	operational mode ..... 21, 26, 27, 29, 31
data output ..... 19	
data output LCD-display ..... 19	<b>P</b>
data storage card ..... 19, 22, 23	particle concentration ..... 18
data storage card battery ..... 24	particle mass ..... 18
data storage card write protection ..... 23	P-line ..... 52
date format ..... 37, 46	power supply ..... 18
detector ..... 10	pressure (range) ..... 18, 68, 70
diluter ..... 28	printer ..... 28, 33
dust collection ..... 18	
dust mass fractions ..... 39	<b>R</b>
<b>E</b>	reproducibility ..... 18
electric safety ..... 8	rinsing air ..... 10, 18
<b>F</b>	RS-232 ..... 16, 21, 30, 33
filter chamber ..... 22, 63	RS-232 cable ..... 16, 33
filter-PTFE ..... 16, 22, 34	RS-232-data transmission ..... 53
<b>G</b>	
glass fuse ..... 9	<b>S</b>
gravimetric control ..... 39	safety ..... 8
<b>I</b>	sample air refeeding ..... 19, 34, 68, 69, 74
interval see storage interval ..... 45	sample flow rate ..... 18
isocinet sampling ..... 17, 34, 67, 68	self-test ..... 10, 19, 37, 38, 50
	sensor ..... 17, 30, 31, 32, 47, 67, 71
	sensor-NanoCheck ..... 17, 67, 73
	sensor-PAH ..... 17, 67, 72
	serial number ..... 22, 34, 47
	signal ground ..... 33
	size channels ..... 18
	sliding average ..... 38
	software ..... 10, 16, 27, 36, 39, 81

spare parts ..... 17, 67  
 standby ..... 24  
 standby mode ..... 21, 26, 29, 46  
 start of measurement ..... 38, 46  
 storage interval ..... 19, 22, 28, 45

**T**

transmission protocol ..... 41

**W**

weather housing, mixer ..... 30  
 weather protection housing ..... 74

**X**

XON/XOFF ..... 41

**Z**

zero filter ..... 16, 70

## Annex

Table 4: Numerical values of the three mass fractions according to the convention EN 481:1993 and for two environmental mass fractions

Aerodynamic diameter [µm]	Inhalable [%]	Thoracic [%]	Respireable (alveolic) [%]	PM-10 [%]	PM-2,5 [%]
0,0	100	100	100	100	100
1,0	97,1	97,1	97,1	100	99,5
2,0	94,3	94,3	91,4	94,2	85,5
2,5					48,0
3,0	91,7	91,7	73,9	92,2	6,7
4,0	89,3	89,0	<b>50,0</b>	89,3	0
5,0	87,0	85,4	30,0	85,7	-
6,0	84,9	80,5	16,8	81,2	-
7,0	82,9	74,2	9,0	75,9	-
8,0	80,9	66,6	4,8	69,7	-
9,0	79,1	58,3	2,5	62,8	-
10,0	77,4	<b>50,0</b>	1,3	55,1	-
11,0	75,8	42,1	0,7	46,5	-
12,0	74,3	34,9	0,4	37,1	-
13,0	72,9	28,6	0,2	26,9	-
14,0	71,6	23,2	0,2	15,9	-
15,0	70,3	18,7	0,1	4,1	-
16,0	69,1	15,0	0	0	-
18,0	67,0	9,5	-	-	-
20,0	65,1	5,9	-	-	-
25,0	61,2	1,8	-	-	-
30,0	58,3	0,6	-	-	-
35,0	56,1	0,1	-	-	-
40,0	54,5	0,1	-	-	-
50,0	52,5	0	-	-	-
60,0	51,4	-	-	-	-
80,0	50,4	-	-	-	-
100,0	<b>50,1</b>	-	-	-	-

Graphical illustration:

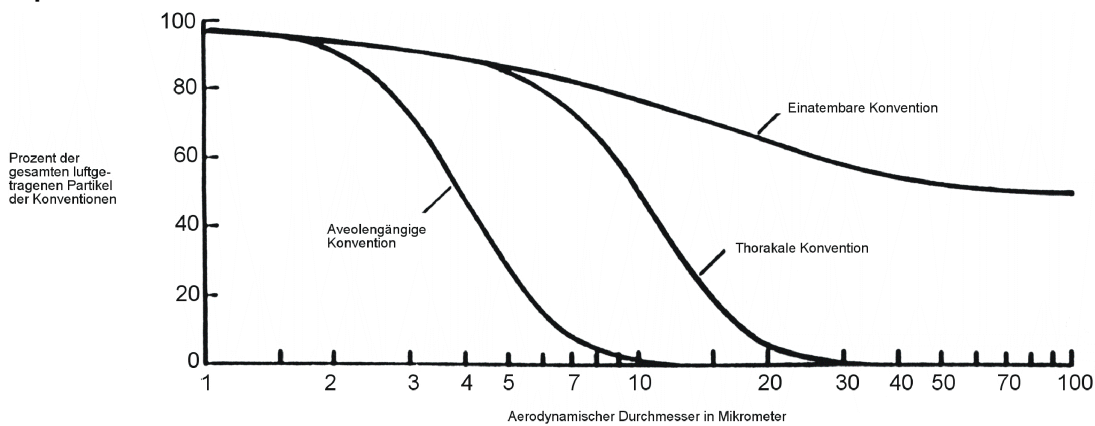

Figure 16: Inhalable, thoracic and alveolic concentration in percent of all airborne particles, according to EN 481:1993, page 5, workplace atmospheres, size fraction definitions.



## 11 Software model 1.178

The revised software 1.178 was introduced in 2010 and is fully compatible with all operating systems under Windows. The former software 1.177 is a 32 bit-Software, respectively the version 1.174 was a 16 bit-software. Annotation: All 1.177 software versions (and prior versions) e.g. 3.20 or 3.00 are compatible to Windows XP and the operation under Windows Vista or Windows 7 was not guaranteed.

The data are displayed numerical or graphical in the following formats:

- *Count distribution:* Particle number concentration for all channels in particles/liter.
- *Occupational health:* Three mass fractions (inhalable, thoracic and respirable (alveolic)) in  $\mu\text{g}/\text{m}^3$ . Values calculated in accordance with the European guideline EN 481, see annex Table 4, on the basis of the mass distribution.
- *Environmental:* Three mass fractions ( $\text{PM}_{10}$ ,  $\text{PM}_{2.5}$  and  $\text{PM}_1$ ) in  $\mu\text{g}/\text{m}^3$ . These values are calculated on the basis of mass distribution and are provided for comparisons of indoor and outdoor measurements, but are not in compliance with US EPA or European approval for equivalent measurements EN 12341 for  $\text{PM}_{10}$ .
- *External sensors:* Depending on type, e.g. temperature, rel humidity, NanoCheck data, velocity.
- *Service data:* Pump current, battery capacity, operational errors, etc..

Grimm's 1.178 Software also offers options for complete statistical analysis of data as well as instrument performance and complete system diagnostics.



For the windows software model 1.178 a separate manual is available.